

## EASY-FILL HOT FOOD WARMER

### OWNERS/SERVICE MANUAL

**WARNING:**

Improper installation, operation, service or maintenance can cause property damage and/or result in personal injury. Read this manual thoroughly before installing, operating, or servicing this equipment.

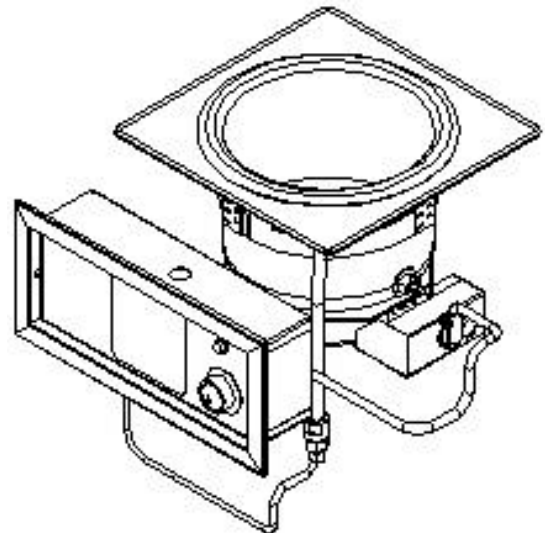

### TABLE OF CONTENTS

Installation .....	2
Operating Instructions .....	3
Cleaning .....	3
Troubleshooting.....	3
Specifications .....	4-7
Replacement Parts List .....	8,9,12,13,16,17,20,21
Exploded View.....	10,14,18,22
Wiring Diagram .....	11,15,19,23
Warranty.....	24

APW Wyott Foodservice Equipment Company  
 729 Third Avenue Dallas, TX 75226  
 (214) 421-7366 FAX (214) 565-0976

## General Installation

1. Always clean equipment thoroughly before use. (See general cleaning instructions.)
2. Check rating label for your model designation & electrical rating.
3. For best results, use stainless steel countertops.
4. All dimensions in parenthesis in centimeters unless noted.

## Installation instructions for EZ well supply line

1. Install P/N 54508, brass fitting in each end of the solenoid using Teflon tape (not supplied).
2. Wrap the threads of the fitting as shown in the illustration, NO. 1.
3. Remove the nut from the brass fitting and the sleeve from the inside of the fitting.
4. Place the sleeve and the nut, nut first, over the 1/4" copper tubing, P/N 54578, supplied with the equipment.
5. Install the line into the solenoid and tighten the nut finger tight.
6. Using a wrench, tighten the nut far enough to crush the sleeve and attach the line. NOTE: Do not over tighten nut. Just enough pressure is required to stop water leaks.
7. Install the 3/8 x 1/4 adapter to the 3/8 stainless steel tube fitting using Teflon tape as shown in illustration NO. 2.
8. Using the other end of the copper tube, install the line, nut, and sleeve to the adapter.
9. Tighten using the same procedure as before.
10. Turn on water supply and look for leaks. If any leaks are found, tighten the nuts until leak is stopped.

**NOTE: With EZ-fill multi-well units, turning on any of the controls will start water to fill all of the wells. To fill, turn one control to the first position and allow all wells to fill completely. After wells are full, set controls to desired settings.**

**INSTALLATION MUST BE DONE BY AUTHORIZED PLUMBER.**

### ILLUSTRATION NO. 1.

#### PART DESCRIPTION:

BRASS CONNECTOR MALE 1/8 NPT x 1/8 TUBE

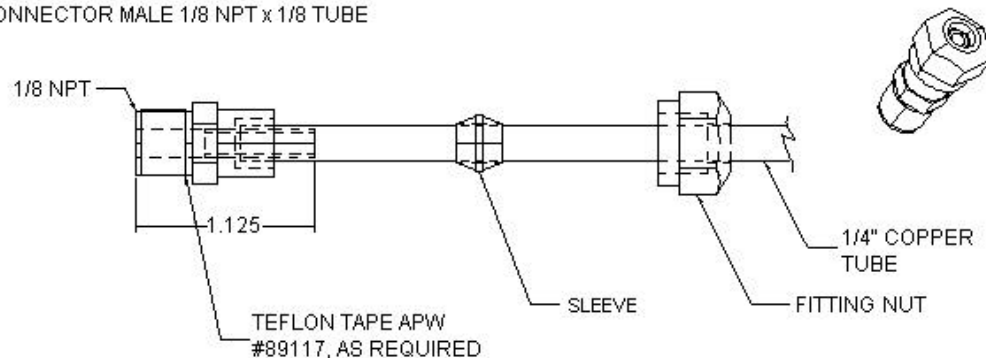

### ILLUSTRATION NO. 2.

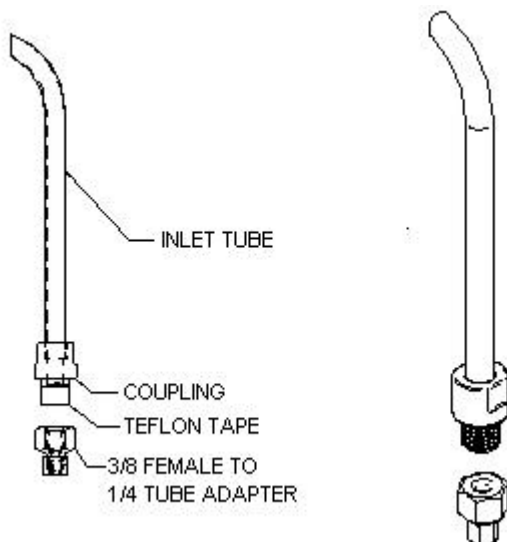

### **General Operation Instructions**

1. All foodservice equipment should be operated by trained personnel.
2. Do not allow your customers to come in contact with any surface labeled "CAUTION HOT."
3. Do not cook, warm or hold food directly in liner pans (well pans). Always use steam table pans / insets, etc. Steam table pan depth should not exceed 6".
4. Never hold food below 150° F (66° C).

### **Wet set-up and operation procedures (Units with drains)**

1. Turn thermostat control to "10" setting or if equipped with infinite controls to "7" or "HI". Preheat for approximately 30 minutes. Pans will fill, to correct level, with water to white probe.
2. Place covered inset with preheated product into well.
3. Readjust control after another 30 minutes of operation to the "6" setting depending on the amount and/or thickness of product.
4. Keep inset / steamtable pan(s) covered to maintain ideal serving temperature.
5. Water is automatically kept at correct level.

**NOTE: Turning on any control will activate autofill.**

### **General Cleaning Instructions**

1. NEVER clean any electrical unit by immersing it in water. Turn off before surface cleaning.
2. Always clean equipment thoroughly before first use. Clean unit daily. Except where noted on charts: Use warm, soapy water. Mild cleansers & PLASTIC scouring pads may be used to remove baked-on food & water scale.
3. Turn off electrical units before cleaning or servicing. All service should be performed by an APW authorized agency.

### **GENERAL TROUBLESHOOTING**

Always Ask & Check:

1. Is the unit connected to a live power source?
2. Check the circuit breaker.
3. Is power switch on & pilot light glowing?
4. Check rating label. Are you operating unit on proper voltage?

If the above checks out, and you still have problems, call an APW authorized service agency.

# APW EZFILL HOT FOOD WELLS

PART NO'S BEGINNING WITH WHFW

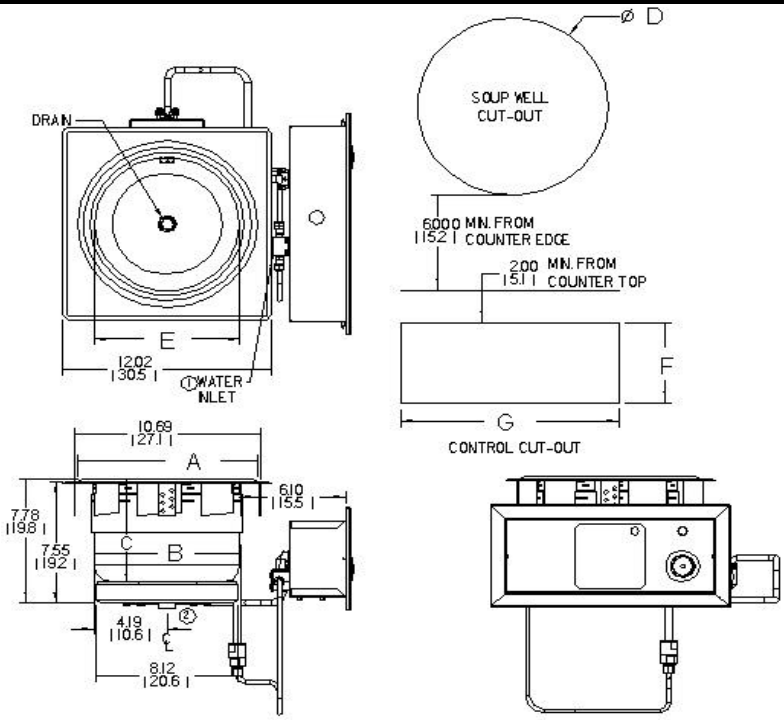
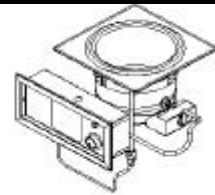

1. Water fill is 3/8 (1.0) tubing connection on left back of left controls
2. Main drain is 3/4 female NPT.

## INSTALLATION

1. Follow general installation instructions on page 3.
  2. Make applicable Cut-Out per above table.  
Note: Unit is designed for installation in stainless steel tops. Optional wood mounting kit available.
  3. Apply putty tape to the underside perimeter of the well rim outer edge.
  4. Apply a 1/4" (.6) bead of silicone sealant adjacent to the putty tape on the well flange.
  5. Drop well into opening from the top and push down until entire parameter of rim is flush with the counter surface.
  6. From below the counter surface insert an 8" to 10" (20 to 25 cm) flat tip screwdriver into the locking ring tab slots and twist in a clockwise motion to lock well in place.
  7. Trim excess putty and sealant from around well rim.
  8. Mount control to front panel using hardware. Maintain 4" (10.2) clearance between well and front panel.
  9. Check nameplate for proper voltage. Connect power.
  10. Connect overflow tube on hot food well to suitable tubing to handle 212 F water. Run to open drain.
- Note: Electrically connect units to comply with local and NEC codes.**

## GENERAL SPECIFICATIONS (APW EZFILL HOT FOOD WELLS)

MODEL	OUTSIDE DIMENSIONS			INSIDE DIMENSIONS	CUT OUT	CONTROL CUT OUT		SHIP WT.
	A	B	C	E	D	F	G	
SM50EZ WELL	10.34" (26.3)	8.38" (21.3)	6.44" (16.4)	8.32" (21.1)	10.875" (27.6)	5.0" (12.7)	12.5" (31.8)	13 Lbs. (5.9 Kg)

## OPTIONS

Description: Lever Operated Drain Valve	Stock No.: 56360	Drain Manifold: Fabricated to Unit, Required
---	------------------	--

## ELECTRICAL SPECIFICATIONS

MODEL	Electrical Ratings 500 @ 208V / 660 @ 240V							
	Volts	Watts	Amps 1-Phase	Max Amps 3-Phase				
SM50EZ WELL	208/240	500/660	2.4 / 2.75	n/a				

NOTE: CUT-OUT SIZES ARE DIFFERENT FROM STANDARD APW HFW'S

## OPERATION

## CLEANING

- |   |  |
|---|--|
| 1. Follow General Operating Instructions on page 3. | 1. Follow General Cleaning Instructions on page 3. |
|---|--|

# APW EZFILL HOT FOOD WELLS

PART NO'S BEGINNING WITH WHFW

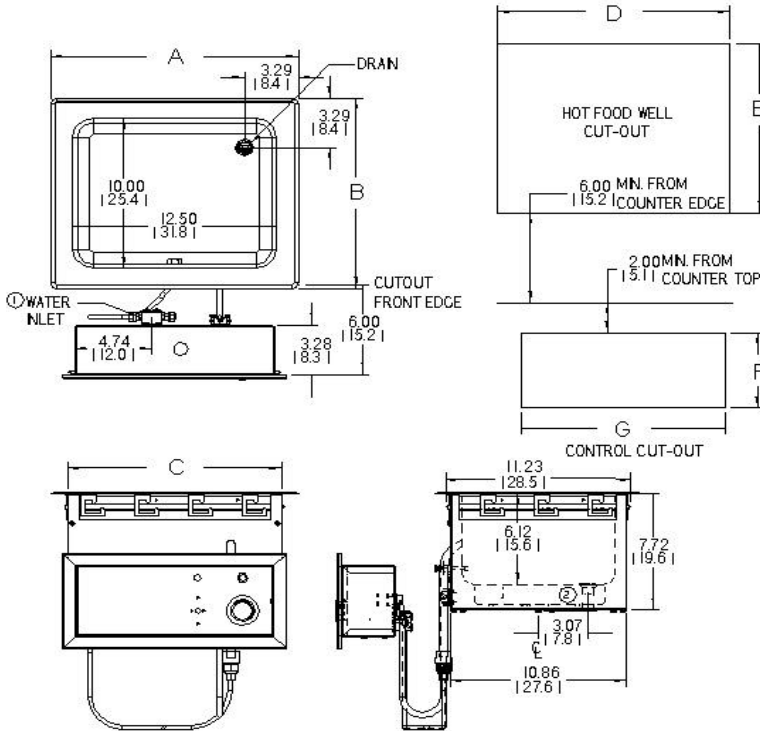
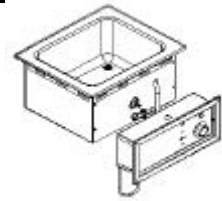

1. Water fill is 3/8 (1.0) tubing connection on left back of left controls
2. Main drain is 3/4 female NPT.

## INSTALLATION

1. Follow general installation instructions on page 3.
  2. Make applicable Cut-Out per above table.  
Note: Unit is designed for installation in stainless steel tops. Optional wood mounting kit available.
  3. Apply putty tape to the underside perimeter of the well rim outer edge.
  4. Apply a 1/4" (.6) bead of silicone sealant adjacent to the putty tape on the well flange.
  5. Drop well into opening from the top and push down until entire parameter of rim is flush with the counter surface.
  6. From below the counter surface insert an 8" to 10" (20 to 25 cm) flat tip screwdriver into the locking ring tab slots and twist in a clockwise motion to lock well in place.
  7. Trim excess putty and sealant from around well rim.
  8. Mount control to front panel using hardware. Maintain 4" (10.2) clearance between well and front panel.
  9. Check nameplate for proper voltage. Connect power.
  10. Connect overflow tube on hot food well to suitable tubing to handle 212 F water. Run to open drain.
- Note: Electrically connect units to comply with local and NEC codes.**

## GENERAL SPECIFICATIONS (APW EZFILL HOT FOOD WELLS)

MODEL	OUTSIDE DIMENSIONS			CUT OUT		CONTROL CUT OUT		SHIP WT.
	A	B	C	D	E	F	G	
SHFWEZ-12D WELL	15.21" (38.6)	12.71" (32.3)	13.49" (34.3)	13.75" (34.9)	11.50" (29.2)	5.0" (12.7)	12.5" (31.8)	22 Lbs. (10.6 Kg)

## OPTIONS

Description: Lever Operated Drain Valve      Stock No.: 56360      Drain Manifold: Fabricated to Unit, Required

## ELECTRICAL SPECIFICATIONS

MODEL	Electrical Ratings 500 EA. @ 208V / 660 EA. @ 240V			
	Volts	Watts	Amps 1-Phase	Max Amps 3-Phase
SHFWEZ-12D WELL	208/240	500/660	2.4/2.75	n/a

NOTE: CUT-OUT SIZES ARE DIFFERENT FROM STANDARD APW HFW'S

## OPERATION

1. Follow General Operating Instructions on page 3.

## CLEANING

1. Follow General Cleaning Instructions on page 3.

# APW EZFILL HOT FOOD WELLS

PART NO'S BEGINNING WITH WHFW



## INSTALLATION

1. Follow general installation instructions on page 3.
  2. Make applicable Cut-Out per above table. Note: Unit is designed for installation in stainless steel tops. Optional wood mounting kit available.
  3. Apply putty tape to the underside perimeter of the well rim outer edge.
  4. Apply a 1/4" (.6) bead of silicone sealant adjacent to the putty tape on the well flange.
  5. Drop well into opening from the top and push down until entire parameter of rim is flush with the counter surface.
  6. From below the counter surface insert an 8" to 10" (20 to 25 cm) flat tip screwdriver into the locking ring tab slots and twist in a clockwise motion to lock well in place.
  7. Trim excess putty and sealant from around well rim.
  8. Mount control to front panel using hardware. Maintain 4" (10.2) clearance between well and front panel.
  9. Check nameplate for proper voltage. Connect power.
  10. Connect overflow tube on hot food well to suitable tubing to handle 212 F water. Run to open drain.
- Note: Electrically connect units to comply with local and NEC codes.**

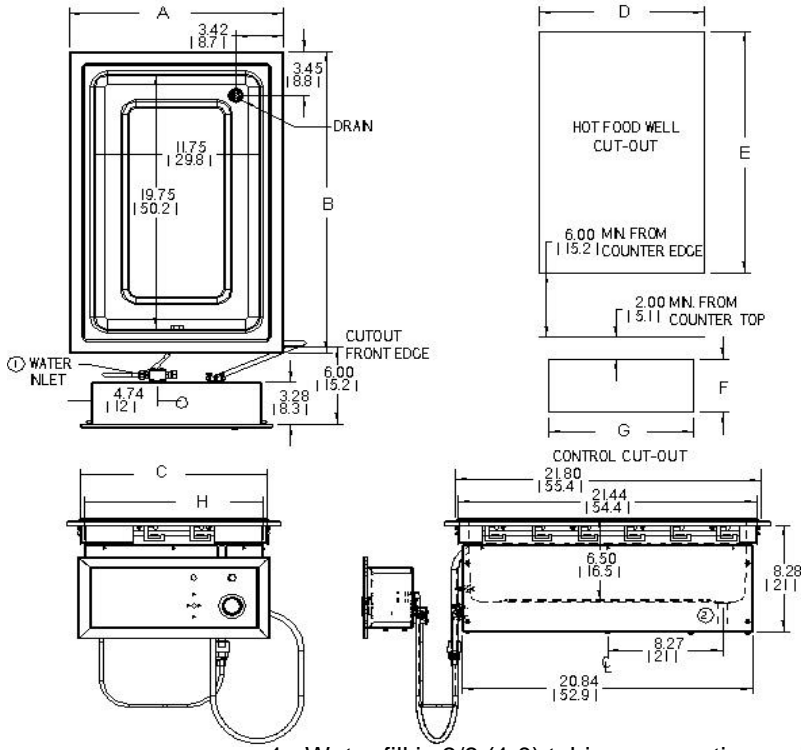

1. Water fill is 3/8 (1.0) tubing connection on left back of left controls
2. Main drain is 3/4 female NPT.

## GENERAL SPECIFICATIONS (APW EZFILL HOT FOOD WELLS)

MODEL	OUTSIDE DIMENSIONS				CUT OUT		CONTROL CUT OUT		SHIP WT.
	A	B	C	H	D	E	F	G	
SHFWEZ-1 WELL	15.38" (39.1)	23.44" (59.5)	13.80" (35.10)	12.85" (32.6)	14.25" (36.2)	22.25" (56.5)	5.0" (12.7)	12.5" (31.8)	24 Lbs. (10.9 Kg)

## OPTIONS

Description: Lever Operated Drain Valve	Stock No.: 56360	Drain Manifold: Fabricated to Unit, Required
---	------------------	--

## ELECTRICAL SPECIFICATIONS

MODEL	Electrical Ratings 1200 EA. @ 208V / 1600 EA. @ 240V				Electrical Ratings 1600 EA. @ 208V			
	Volts	Watts	Amps 1-Phase	Max Amps 3-Phase	Volts	Watts	Amps 1-Phase	Amps 3-Phase
SHFWEZ-1 WELL	208/240	1200/1600	5.8 / 6.7	n/a	208	1600	7.7	n/a

NOTE: CUT-OUT SIZES ARE DIFFERENT FROM STANDARD APW HFWS

## OPERATION

1. Follow General Operating Instructions on page 3.

## CLEANING

1. Follow General Cleaning Instructions on page 3.

# APW EZFILL HOT FOOD WELLS

PART NO'S BEGINNING WITH WHFW

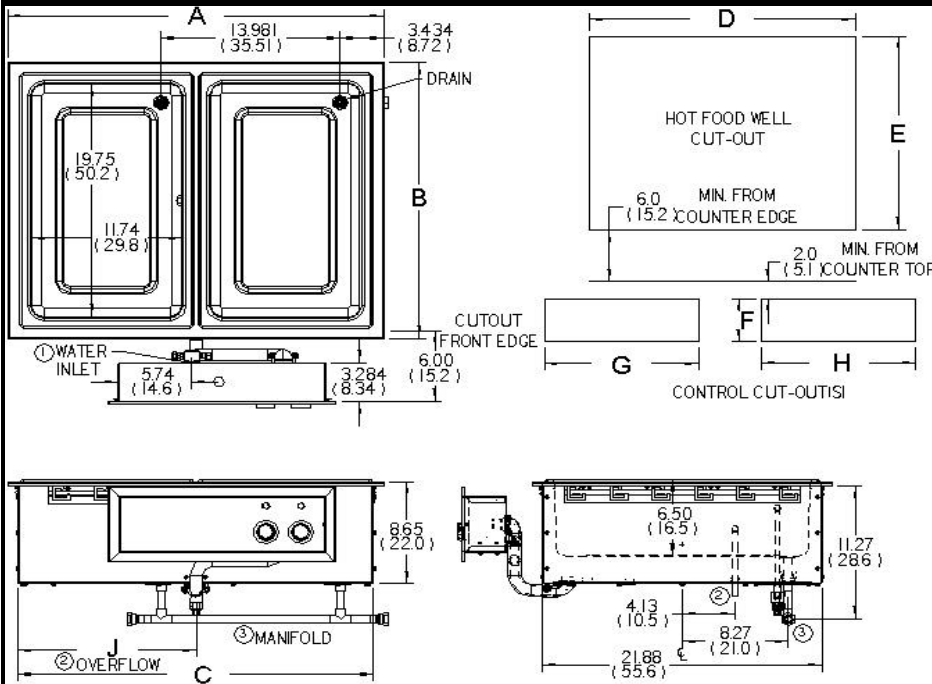
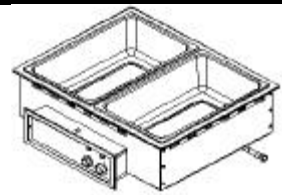

## INSTALLATION

1. Follow general installation instructions on page 3.
  2. Make applicable Cut-Out per above table. Note: Unit is designed for installation in stainless steel tops. Optional wood mounting kit available.
  3. Apply putty tape to the underside perimeter of the well rim outer edge.
  4. Apply a 1/4" (.6) bead of silicone sealant adjacent to the putty tape on the well flange.
  5. Drop well into opening from the top and push down until entire parameter of rim is flush with the counter surface.
  6. From below the counter surface insert an 8" to 10" (20 to 25 cm) flat tip screwdriver into the locking ring tab slots and twist in a clockwise motion to lock well in place.
  7. Trim excess putty and sealant from around well rim.
  8. Mount control to front panel using hardware. Maintain 4" (10.2) clearance between well and front panel.
  9. Check nameplate for proper voltage. Connect power.
  10. Connect overflow tube on hot food well to suitable tubing to handle 212 F water. Run to open drain.
- Note: Electrically connect units to comply with local and NEC codes.**

1. Water fill is 3/8 (1.0) tubing connection on left back of left controls
2. Overflow drain is 1/2" (1.3) OD tube outlet.
3. Main drain is 3/4 female NPT.

## GENERAL SPECIFICATIONS (APW EZFILL HOT FOOD WELLS)

MODEL	OUTSIDE DIMENSIONS				CUT OUT		CONTROL CUT OUT			SHIP WT.
	A	B	C	J Overflow	D	E	F	G	H	
SHFWEZ-2D WELL	29.42" (74.2)	23.44" (59.5)	27.79" (70.6)	13.87" (35.2)	28.5" (72.4)	22.5" (57.2)	5.0" (12.7)	16.50" (41.9)	n/a	48 Lbs. (21.8 Kg)
SHFWEZ-3D WELL	43.46" (110.4)	23.44" (59.5)	41.83" (106.2)	27.92" (70.9)	42.5" (108.0)	22.5" (57.2)	5.0" (12.7)	33.50" (85.1)	12.50"	68 Lbs. (30.8 Kg)
SHFWEZ-4D WELL	57.50" (146.0)	23.44" (59.5)	55.87" (141.9)	27.92" (70.9)	56.5" (143.5)	22.5" (57.2)	5.0" (12.7)	16.50" (41.9)	n/a	98 Lbs. (44.4 Kg)
SHFWEZ-5D WELL	71.54" (181.7)	23.44" (59.5)	69.92" (177.6)	41.96" (106.6)	70.5" (179.1)	22.5" (57.2)	5.0" (12.7)	33.50" (85.1)	n/a	118 Lbs. (53.5 Kg)
SHFWEZ-6D WELL	85.59" (217.4)	23.44" (59.5)	83.96" (213.2)	41.96" (106.6)	84.50" (214.6)	22.5" (57.2)	5.0" (12.7)	33.50" (85.1)	n/a	260 Lbs. (117.9 Kg)

## OPTIONS

Description: Lever Operated Drain Valve      Stock No.: 56360      Drain Manifold: Fabricated to Unit, Required

## ELECTRICAL SPECIFICATIONS

MODEL	Electrical Ratings 1200 EA. @ 208V / 1600 EA. @ 240V				Electrical Ratings 1600 EA. @ 208V			
	Volts	Watts	Amps 1-Phase	Max Amps 3-Phase	Volts	Watts	Amps 1-Phase	Amps 3-Phase
SHFWEZ-2D	208/240	2400/3200	12 / 14	10 / 12	208	3200	16	14
SHFWEZ-3D	208/240	3600/4800	18 / 20	10 / 12	208	4800	23	14
SHFWEZ-4D	208/240	4800/6400	24 / 27	16 / 18	208	6400	31	21
SHFWEZ-5D	208/240	6000/8000	29 / 34	20 / 24	208	8000	39	27
SHFWEZ-6D	208/240	7200/9600	35 / 40	20 / 24	208	9600	47	27

NOTE: CUT-OUT SIZES ARE DIFFERENT FROM STANDARD APW HFW'S

## OPERATION

1. Follow General Operating Instructions on page 3.

## CLEANING

1. Follow General Cleaning Instructions on page 3.



REPLACEMENT PARTS CATALOG

**SM50EZ**

**ROUND SOUP WELL DROP-IN WITH EZ LOCK**

**SM50EZ, P/N EZSM50-7D – 208/240V-500/660W**

**SM50EZ  
EZ FILL MULTI WELLS,**

ITEM STOCK

NO.	NO.	DESCRIPTION
1	54561	CONTROL BOX W/ASSY 12.50 "
2	54503	BEZEL CONTROL 12.50 "
3	56527	THERMOSTAT 36" CAPILLARY
4	56528	KNOB, BLACK
5	63012	INDICATOR LIGHT (56530)
6	54577	ADAPTER, 1/4" TUBE TO 3/8 PIPE
7	54578	TUBING, COPPER, 1/4"
8	55343	90 DEGREE CONDUIT CONNECTOR
9	54511	OCTAL BASE USE WITH 54510
10	54524	BRACKET, SOLENOID VALVE
11	54513	WATER SOLENOID VALVE
12	54510	LIQUID LEVEL CONTROL OCTAL BASE
	XXXX	LIQUID LEVEL CONTROL OPEN BOARD
13	54512	HOLD DOWN STRAP USE WITH 54510
14	30201	TERMINAL BLOCK
15	54508	BRASS FITTING 1/8 NPT X 1/4 COMPRESSION
16	54572	7 QT. ROUND WELL PAN W/COPPER TUBE
17	50817	PLATE, HEAT DIFFUSER
18	55964	HEATING ELEMENT 208/240V, 500W/660W
19	55696	BRACKET, ELEMENT HOLDER
20	55695	BRACKET, ELEMENT HOLDER
21	89025	10-24 SPEED NUT
22	55992	BOTTOM COVER
23	89059	#10 EXTERNAL LOCK WASHER
24	89061	NUT,HEX 10-24
25	54544	O-RING FOR PROBE HOLDER
26	54543	PROBE HOLDER

ITEM STOCK

NO.	NO.	DESCRIPTION
27	54546	WASHER 1/20 SS
28	54549	NUT, HEX 1/2-20
29	54545	O-RING FOR SCREW
30	88971	SCREW 8-32 X 1-1/2 SS
31	54548	SPACER, PROBE HOLDER
32	89063	NUT, HEX 8-32
33	56542	PLATE, DIAL-WELLS
34	88961	10-24 HEX NUT, GREEN-GROUND
35	89054	6-32 KEPS NUT
36	88993	10-32 X 3/8 TRUSS HEAD SCREW
37	89073	#8 X 1/2 SHEET METAL SCREW
38	51016	COVER, TERMINAL
39	55342	3/8" CONDUIT
40	55340	ANTI-SHORT BUSHING
41	89120	JIFFY CLIP
42	88889	8 X 1/4" AB SMS, PHL TRUSS
43	88977	6-32 X 1.0 SLOTTED PAN HEAD
44	55333	WOOD MOUNT KIT SM-50-7
45	55402	EZ LOCK CLIP 4 TAB

HARDWARE NOT SHOWN

56655	DRAIN STRAINER
54532	WIRE SET TWO WELL
54533	WIRE SET THREE WELL
54534	WIRE SET FOUR WELL
54535	WIRE SET FIVE WELL
54536	WIRE SET SIX WELL

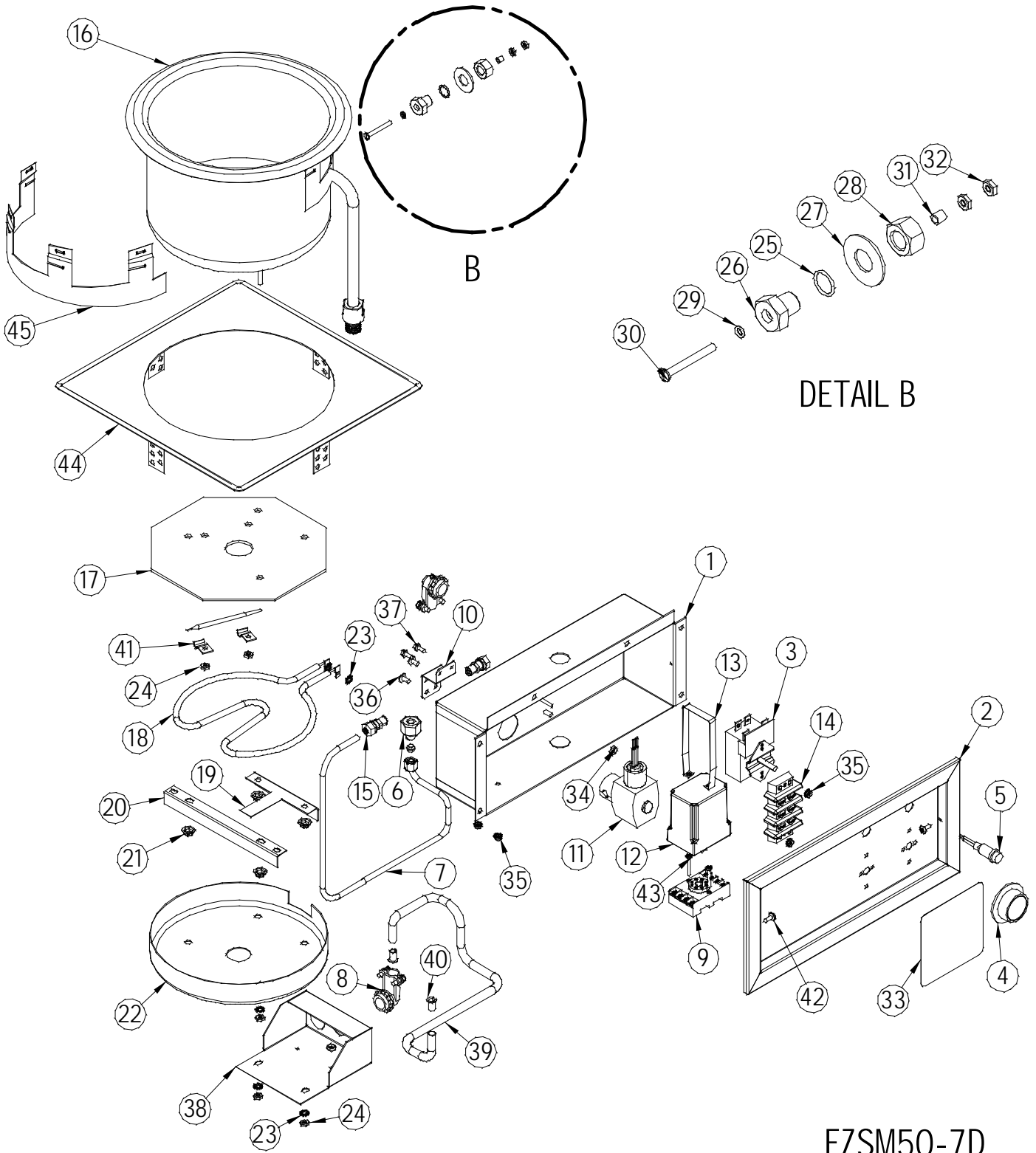

EZSM50-7D

# SM-50 WIRING DIAGRAM

AMERICAN PERMANENT WARE, INC.  
729 THIRD AVENUE  
DALLAS, TX. 75226

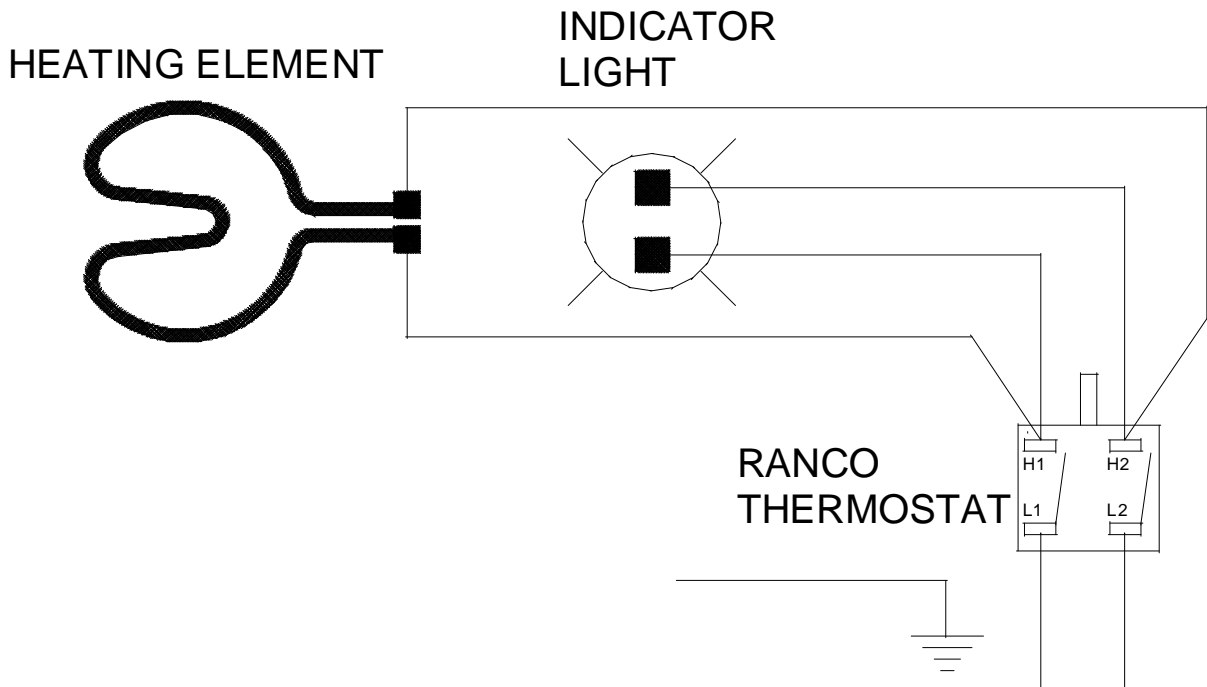
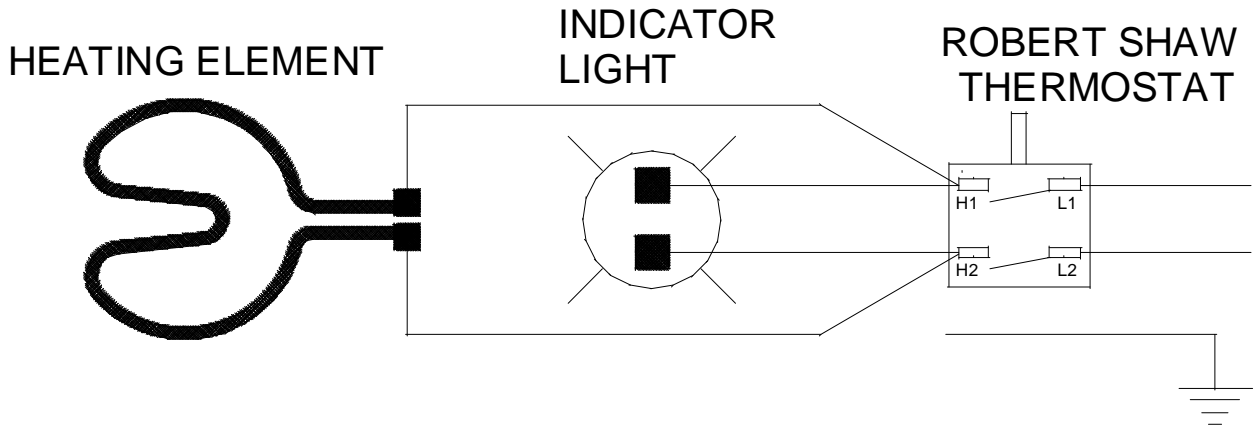



REPLACEMENT PARTS CATALOG

**EZ12D4B**

**SMALL FRAME INSULATED TOP MOUNT EZ FILL HOT FOOD WELLS**

**HFWEZ12D, P/N EZ12D4B – 208/240V-500/660W**

**HFWEZ12D  
EZ FILL MULTI WELLS,**

ITEM STOCK

NO.	NO.	DESCRIPTION
1	54561	CONTROL BOX W/ASSY 12.50 "
2	55342	3/8" CONDUIT
3	55340	ANTI-SHORT BUSHING
4	54578	TUBING, COPPER, 1/4
5	88889	8 X 1/4" AB SMS, PHL TRUSS
6	54508	BRASS FITTING 1/8 NPT X 1/4 COMPRESSION
7	56406	WRAPPER, 1/2" SIZE OUTER
8	54567	1/2" SIZE WELL PAN W/COPPER TUBE
9	54571	WRAPPER OUTER END
10	30201	TERMINAL BLOCK
11	56505	KNOB, BLACK
12	88977	6-32 X 1.0 SLOTTED PAN HEAD
13	89054	6-32 KEPS NUT
14	54546	WASHER 1/20 SS
15	54549	NUT, HEX 1/2-20
16	54543	PROBE HOLDER
17	88971	SCREW 8-32 X 1-1/2 SS
18	54548	SPACER, PROBE HOLDER
19	89073	#8 X 1/2 SHEET METAL SCREW
20	88993	10-32 X 3/8 TRUSS HEAD SCREW
21	89063	NUT, HEX 8-32
22	54544	O-RING FOR PROBE HOLDER
23	54545	O-RING FOR SCREW
24	50817	PLATE, HEAT DIFFUSER
25	55964	HEATING ELEMENT 208/240V, 500W/660W
26	55695	BRACKET, ELEMENT HOLDER
27	55696	BRACKET, ELEMENT HOLDER
28	55992	BOTTOM COVER
29	56404	BOTTOM COVER
30	56655	DRAIN STRAINER

ITEM STOCK

NO.	NO.	DESCRIPTION
31	88961	10-24 HEX NUT, GREEN-GROUND
32	89025	10-24 SPEED NUT
33	89059	#10 EXTERNAL LOCK WASHER
34	89061	NUT, HEX 10-24
35	55343	90 DEGREE CONDUIT CONNECTOR
36	89120	JIFFY CLIP
37	54511	OCTAL BASE USE WITH 54510
38	54524	BRACKET, SOLENOID VALVE
39	54513	WATER SOLENOID VALVE
40	54510	LIQUID LEVEL CONTROL OCTAL BASE XXXX
41	54512	HOLD DOWN STRAP USE WITH 54510
42	54503	BEZEL CONTROL 12.50 "
43	56527	THERMOSTAT 36" CAPILLARY
44	56536	INDICATOR LIGHT (56530)
45	54577	ADAPTER, 1/2" TUBE TO 3/8 PIPE
46	56945	INSULATION 12X9X1/2
47	56412	INSULATION 12X9X1/2
48	56411	INSULATION 12X9X1/2
49	55305	EZ LOCK, 4 TAB
50	56402	EZ LOCK 1/4" WARMER
51	56388	PLATE, HOLE COVER

HARDWARE NOT SHOWN

56542	PLATE, DIAL-WELLS
54532	WIRE SET TWO WELL
54533	WIRE SET THREE WELL
54534	WIRE SET FOUR WELL
54535	WIRE SET FIVE WELL
54536	WIRE SET SIX WELL

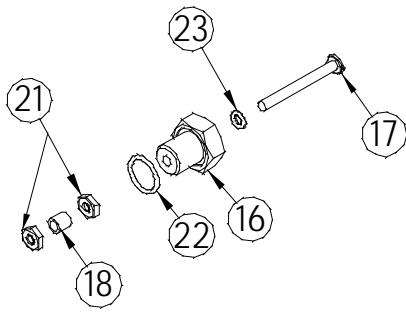

DETAIL C

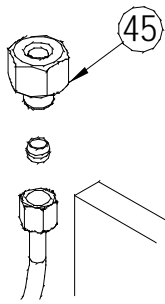

DETAIL D

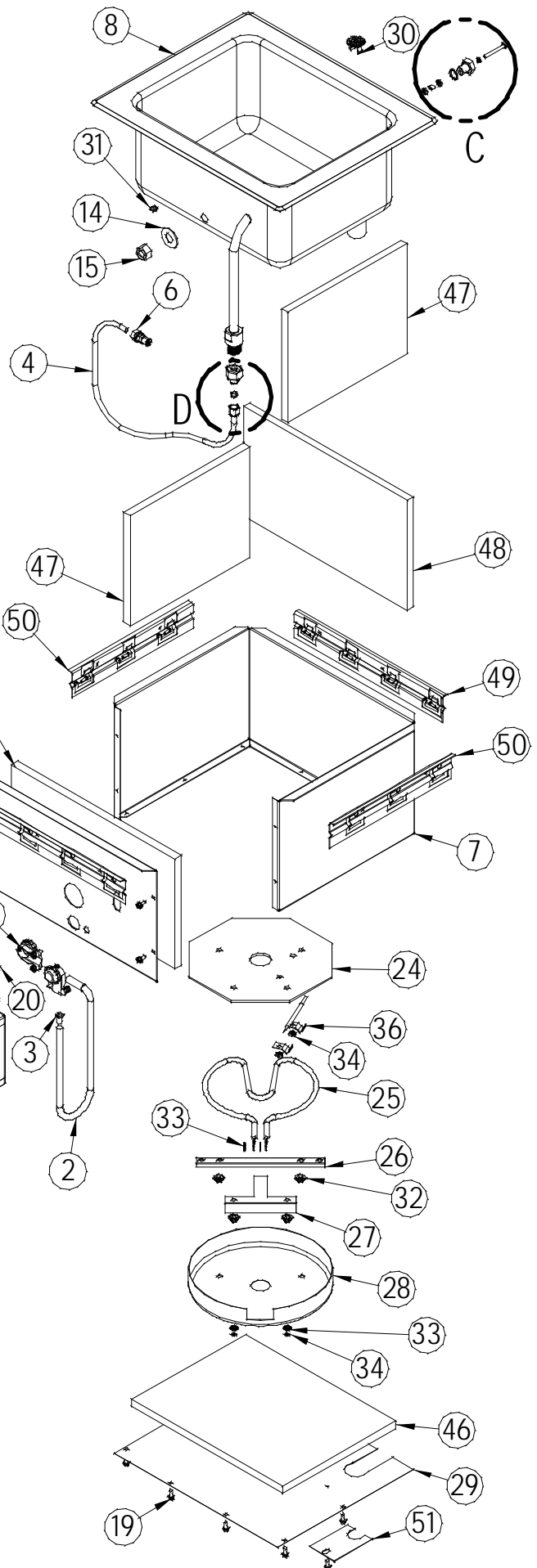

# HFWEZ12D

# HFW-12 WIRING DIAGRAM

AMERICAN PERMANENT WARE, INC.  
729 THIRD AVENUE  
DALLAS, TX. 75226

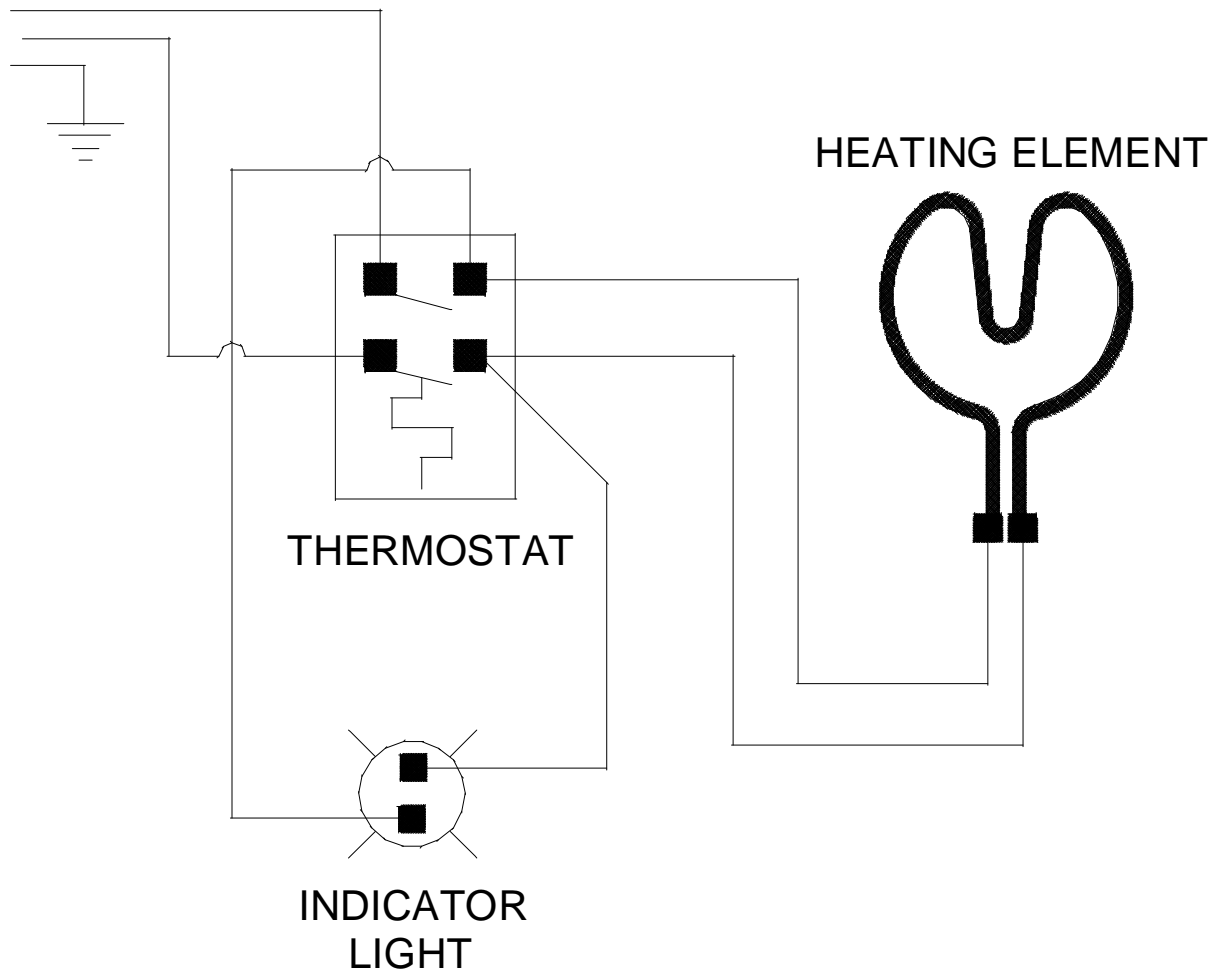



REPLACEMENT PARTS CATALOG

**HFWEZ-1**

**SMALL FRAME INSULATED TOP MOUNT EZ FILL HOT FOOD WELLS**

**SHFWEZ-1D, P/N EZ1D2B - 208V-1600W**

**SHFWEZ-1D, P/N EZ1D4B - 208/240V-1200/1600W**

**HFW-1D  
EZ FILL MULTI WELLS,**

ITEM STOCK

**NO. NO. DESCRIPTION**

1	54551	BASE
2	54555	COVER, BOTTOM
3	55308	E-Z LOCK, 6 TAB
4	55340	ANTI-SHORT BUSHING
5	54554	WRAPPER, END
6	54557	BRACKET, WRAPPER END
7	54556	E-Z LOCK, 2 TAB
8	56515	INSULATION, 20-3/8X8X1/2
9	56516	INSULATION, 13X8X1/2
10	89063	NUT, HEX 8-32
11	56513	INSULATION, 18X12X1
12	30201	TERMINAL BLOCK
13	56505	KNOB, THERMOSTAT
14	88977	6-32 X 1.0 SLOTTED PAN HEAD
15	89054	6-32 KEPS NUT
16	54549	NUT, HEX 1/2-20
17	54545	O-RING FOR SCREW
18	89061	10-24 HEX NUT
19	56521	RIVET, POP
20	89025	10-24 SPEED NUT
21	89073	#8 X 1/2 SHEET METAL SCREW
22	88889	8 X 1/4 AB SMS, PHL TRUSS
23	54552	WRAPPER, SIDE
24	54558	BRACKET, WRAPPER SIDE
25	55789	SEALANT, PERMAGUM
26	54564	HOLE COVER
27	54559	WELL PAN W/ASSY (W/COPPER TUBES
28	89120	JIFFY CLIP
29	56039	CAPILLARY COVER FOR T'STATS
30	56506	REFLECTOR PAN
31	55441	HEATING ELEMENT 208/240V, 1200W/1600W
32	54544	O-RING FOR PROBE HOLDER)
33	54543	PROBE HOLDER
34	54546	WASHER 1/20 SS
35	88971	SCREW 8-32 X 1-1/2 SS
36	54548	SPACER, PROBE HOLDER

ITEM STOCK

**NO. NO. DESCRIPTION**

37	56655	DRAIN STRAINER
38	54561	CONTROL BOX W/ASSY 12.50 "
39	54511	OCTAL BASE USE WITH 54510
40	54524	BRACKET, SOLENOID VALVE
41	54513	WATER SOLENOID VALVE
42	54510	LIQUID LEVEL CONTROL OCTAL BASE
	XXXX	LIQUID LEVEL CONTROL OPEN BOARD
43	54512	HOLD DOWN STRAP USE WITH 54510
44	54503	BEZEL CONTROL 12.50 "
45	54521	BEZEL CONTROL 16.50 "
46	54529	BEZEL CONTROL 33.50 "
47	56527	THERMOSTAT 36" CAPILLARY
48	56536	INDICATOR LIGHT (56530)
49	55343	90 DEGREE CONDUIT CONNECTOR
50	88993	10-32 X 3/8 TRUSS HEAD SCREW
51	55342	3/8" CONDUIT
52	54553	WRAPPER, CONTROL END
53	54508	BRASS FITTING 1/8 NPT X 1/4 COMPRESSION
54	54578	TUBING, COPPER, 1/4
55	89059	#10 EXTERNAL LOCKWASHER
56	54577	ADAPTER, 1/4" TUBE TO 3/8 PIPE
57	56388	PLATE, HOLE COVER
58		HARDWARE NOT SHOWN
59	88961	10-24 HEX NUT, GREEN-GROUND
60	56542	DIAL PLATE
61	54532	WIRE SET TWO WELL
62	54533	WIRE SET THREE WELL
63	54534	WIRE SET FOUR WELL
64	54535	WIRE SET FIVE WELL
65	54536	WIRE SET SIX WELL

# DETAIL B

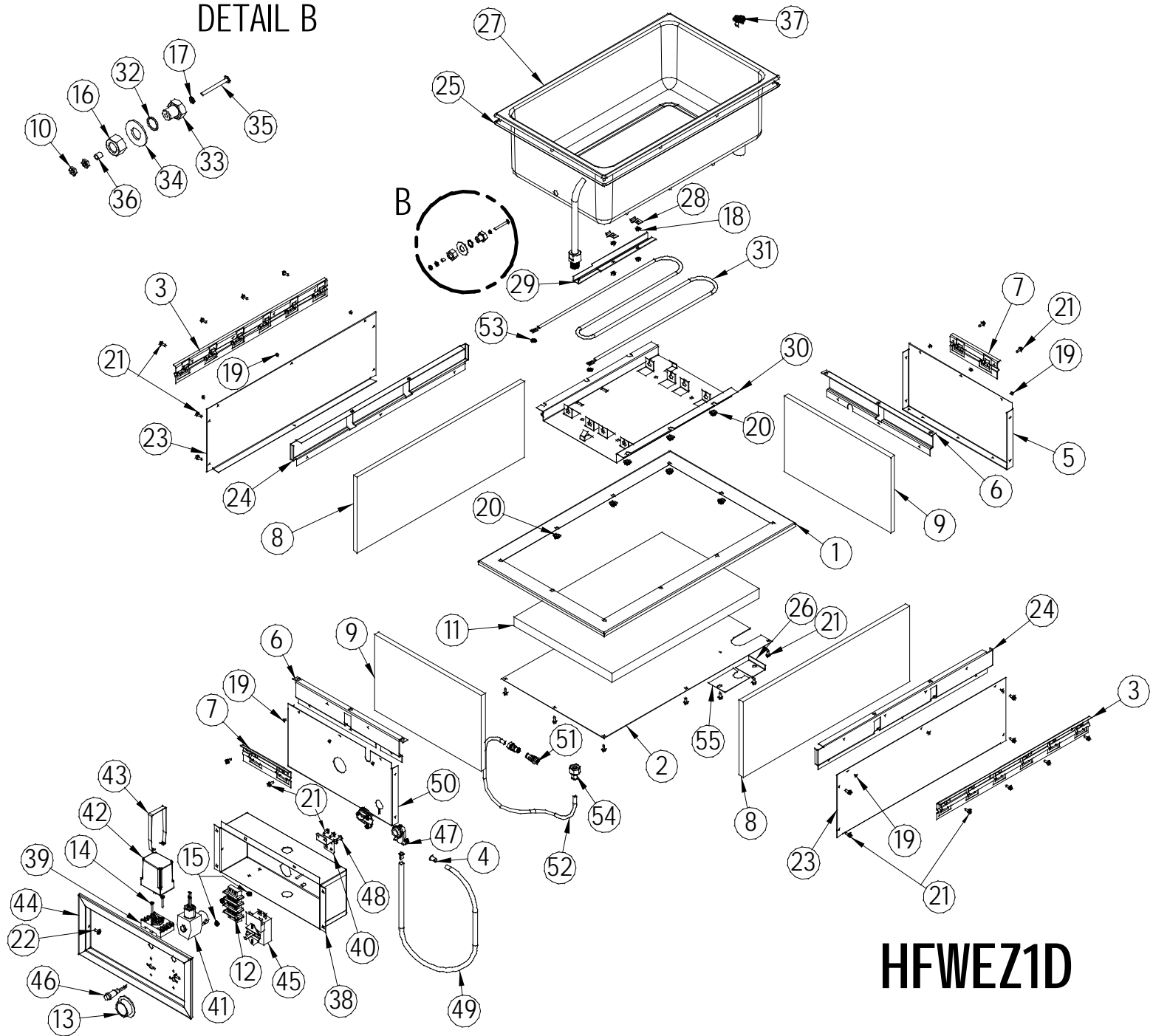

# HFWEZ1D

# THERMOSTATIC CONTROL CONFIGURATION

## HEATING ELEMENTS

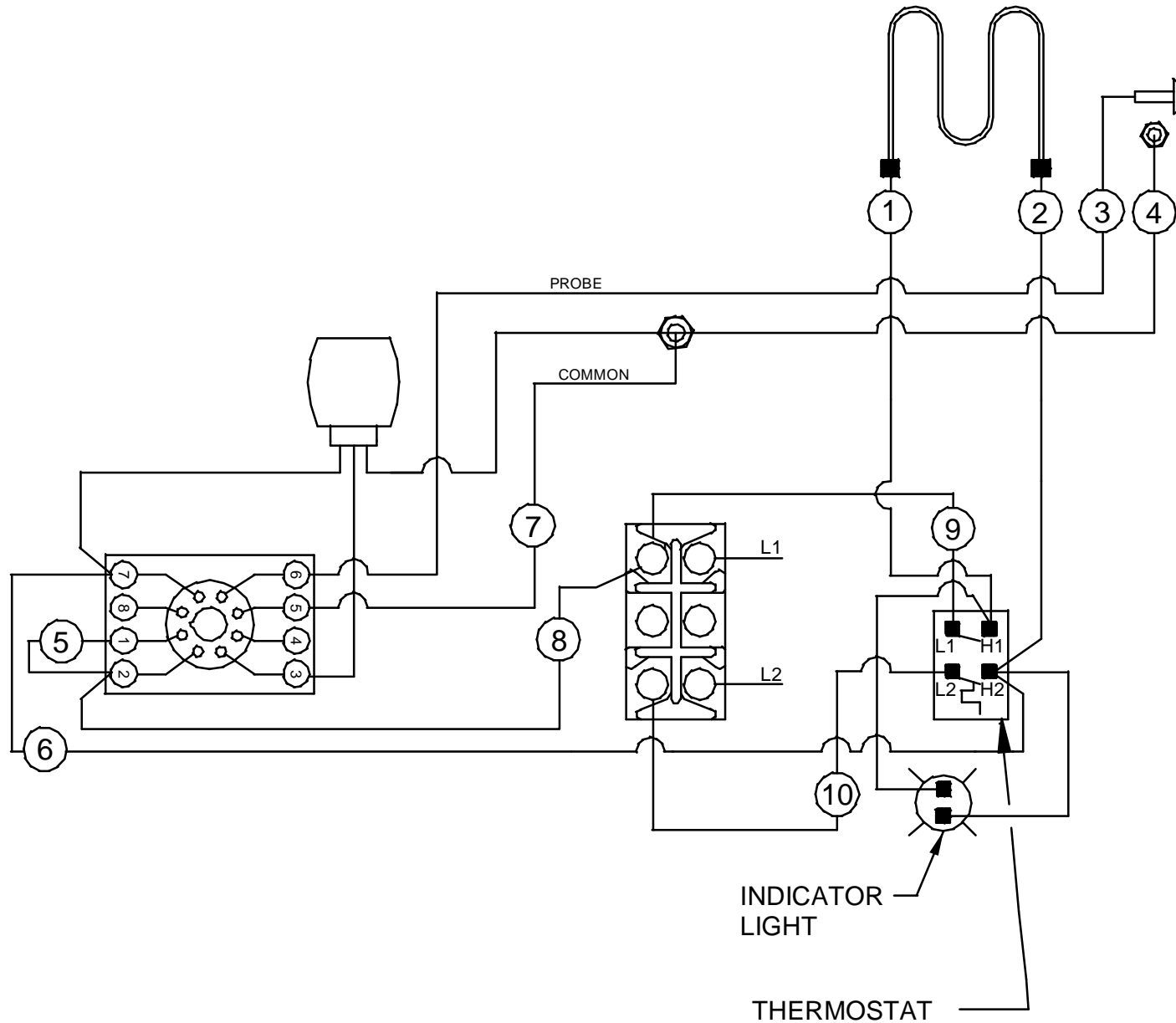



REPLACEMENT PARTS CATALOG

**HFWEZ-2, HFWEZ-3, HFWEZ-4,  
HFWEZ-5, HFWEZ-6**

**SMALL FRAME INSULATED TOP MOUNT EZ FILL HOT FOOD WELLS**

**HFWEZ-2D, P/N EZ2D2B - 208V-1600W  
HFWEZ-2D, P/N EZ2D4B - 208/240V-1200/1600W**

**HFWEZ-3D, P/N EZ3D2B - 208V-1600W  
HFWEZ-3D, P/N EZ3D4B - 208/240V-1200/1600W**

**HFWEZ-4D, P/N EZ4D2B - 208V-1600W  
HFWEZ-4D, P/N EZ4D4B - 208/240V-1200/1600W**

**HFWEZ-5D, P/N EZ5D2B - 208V-1600W  
HFWEZ-5D, P/N EZ5D4B - 208/240V-1200/1600W**

**HFWEZ-6D, P/N EZ6D2B - 208V-1600W  
HFWEZ-6D, P/N EZ6D4B - 208/240V-1200/1600W**

**HFW-2D THROUGH HFW-6D  
EZ FILL MULTI WELLS,**

ITEM STOCK

NO.	NO.	DESCRIPTION
1	54575	WELL PAN W/ASSY (W/COPPER TUBES)
2	55789	SEALANT, PERMAGUM
3	54518	WELL PAN W/ASSY (W/O TUBES)
4	56655	DRAIN STRAINER
5	88971	SCREW 8-32 X 1-1/2 SS
6	54545	O-RING FOR SCREW
7	54543	PROBE HOLDER
8	54544	O-RING FOR PROBE HOLDER
9	89063	NUT, HEX 8-32
10	54548	SPACER, PROBE HOLDER
11	54546	WASHER 1/20 SS
12	54549	NUT, HEX 1/2-20
13	57264	WELL BRACE
14	54577	ADAPTER, 1/4" TUBE TO 3/8" PIPE
15	55441	HEATING ELEMENT 208/240V, 1200W/1600W
	54051	HEATING ELEMENT 208V/1600W
16	89059	#10 EXTERNAL LOCKWASHER
17	89120	JIFFY CLIP
18	89061	10-24 HEX NUT
19	56039	CAPILLARY COVER FOR T'STATS
20	56506	REFLECTOR PAN
21	89025	10-24 SPEED NUT
22	57252	2 WELL TOP PLATE
	57260	3 WELL TOP PLATE
	57263	4 WELL TOP PLATE
	57290	5 WELL TOP PLATE
	57363	6 WELL TOP PLATE
23	89073	#8 X 1/2 SHEET METAL SCREW
24	55308	E-Z LOCK, 6 TAB
25	56050	END COVER
26	56048	CONDUIT BRACE
27	57254	2 WELL FRONT OR BACK COVER
	57262	3 WELL FRONT OR BACK COVER
	57266	4 WELL FRONT OR BACK COVER
	57292	5 WELL FRONT OR BACK COVER
	57365	6 WELL FRONT OR BACK COVER
28	60150	1" X 7" X 48" INSULATION HIGH TEMP
29	56388	HOLE COVER
30	54526	2 WELL BOTTOM COVER
	54538	3 WELL BOTTOM COVER
	54539	4 WELL BOTTOM COVER
	54540	5 WELL BOTTOM COVER
	54541	6 WELL BOTTOM COVER
31	54524	BRACKET, SOLENOID VALVE

ITEM STOCK

NO.	NO.	DESCRIPTION
32	54508	BRASS FITTING 1/8 NPT X 1/4 COMPRESSION
33	54504	CONTROL BOX W/ASSY 12.50 "
	54522	CONTROL BOX W/ASSY 16.50 "
	54529	CONTROL BOX W/ASSY 33.50 "
34	54512	HOLD DOWN STRAP USE WITH 54510
35	54510	LIQUID LEVEL CONTROL OCTAL BASE
	XXXX	LIQUID LEVEL CONTROL OPEN BOARD
36	88977	6-32 X 1.0 SLOTTED PAN HEAD
37	54511	OCTAL BASE USE WITH 54510
38	54503	BEZEL CONTROL 12.50 "
	54521	BEZEL CONTROL 16.50 "
	54529	BEZEL CONTROL 33.50 "
39	88889	8 X 1/4" B SMS, PHL TRUSS
40	56536	INDICATOR LIGHT (56530)
41	56505	KNOB, THERMOSTAT
42	89054	6-32 KEPS NUT
43	54513	WATER SOLENOID VALVE
44	30201	TERMINAL BLOCK
45	56540	THERMOSTAT 72" CAPILLARY
46	56527	THERMOSTAT 36" CAPILLARY
47	55099	3/4" CONDUIT 24" LONG
48	55058	90 DEGREE CONDUIT CONNECTOR
49	88993	10-32 X 3/8 TRUSS HEAD SCREW
50	55059	ANTI-SHORT BUSHING
51	87822	WASHER REDUCING 1 X 3/4
52	89184	7/8" HOLE BUSHING
53	57258	2 WELL DRAIN MANIFOLD
	57273	3 WELL DRAIN MANIFOLD
	57267	4 WELL DRAIN MANIFOLD
	57293	5 WELL DRAIN MANIFOLD
	57366	6 WELL DRAIN MANIFOLD

HARDWARE NOT SHOWN

88961	10-24 HEX NUT, GREEN-GROUND
54578	TUBING, COPPER
56542	DIAL PLATE
54532	WIRE SET TWO WELL
54533	WIRE SET THREE WELL
54534	WIRE SET FOUR WELL
54535	WIRE SET FIVE WELL
54536	WIRE SET SIX WELL

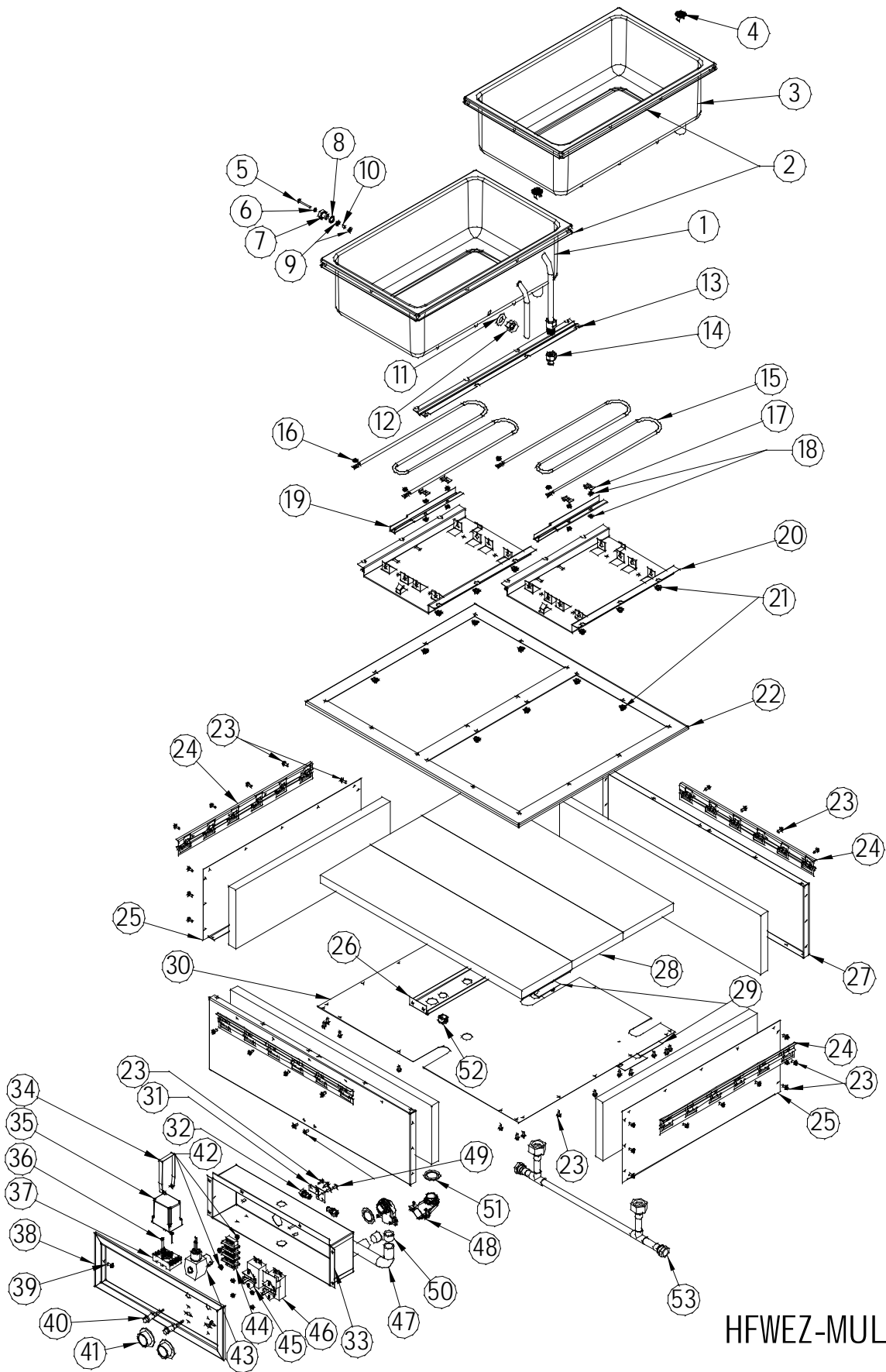

HFWEZ-MULTIWELLS

# EZ-FILL WIRING DIAGRAM

AMERICAN PERMANENT WARE, INC.  
729 THIRD AVENUE  
DALLAS, TX. 75226

## THERMOSTATIC CONTROL CONFIGURATION

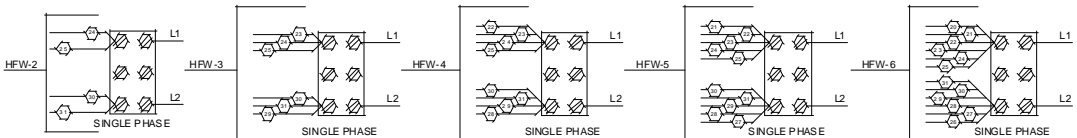
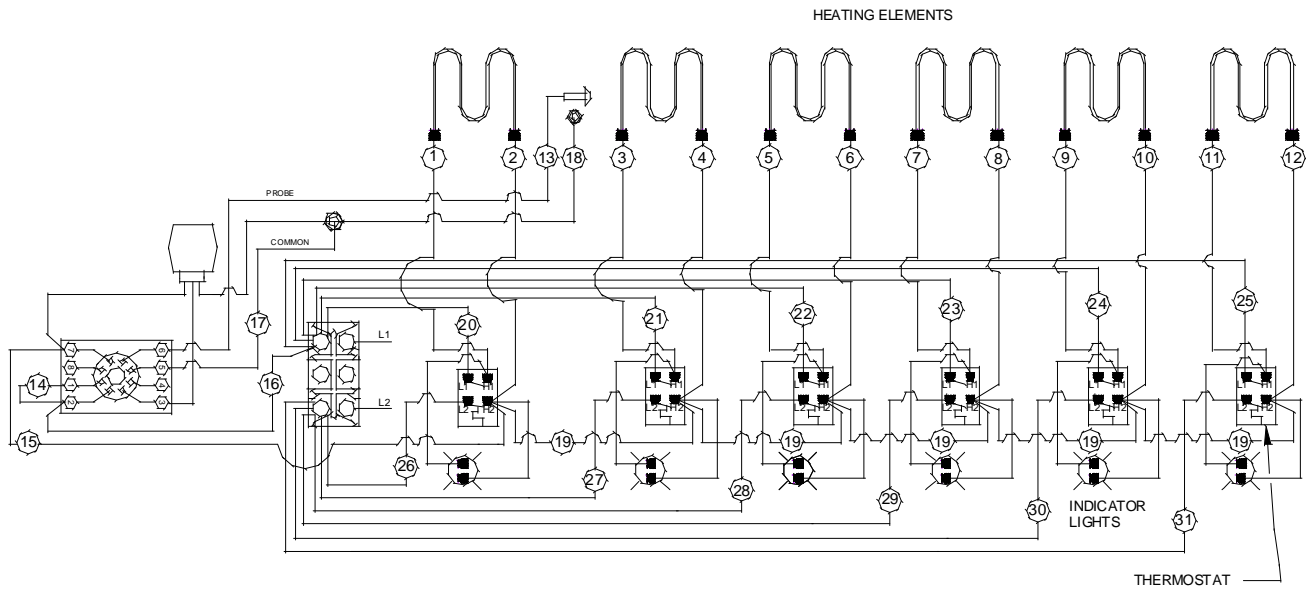
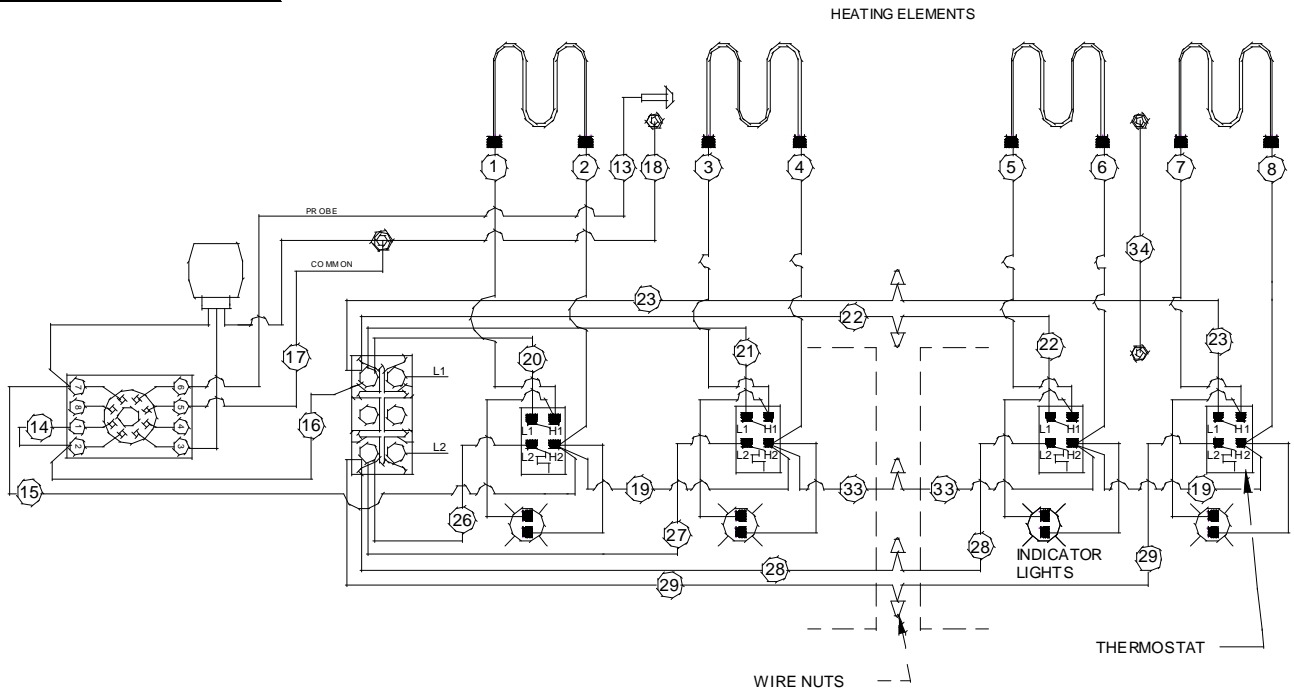

67172WD

## Warranty Policy

APW Wyott warrants to the original owner/user that all commercial cooking equipment shall be free of defects in material and workmanship under normal use and service for a period of one year from the original date of purchase. Warranty service will be provided on the customer's premises for APW Wyott equipment. This warranty includes parts, standard straight time labor charges, approved travel time charges and approved mileage, and excludes all other charges. This warranty does not cover any cost associated with installation or calibration, or any damages resulting from accident, alteration, misuse, abuse, negligence, wrong voltage, flood, fire, acts of God, improper installation, failure to properly maintain or failure to operate strictly in accordance with instructions and does not apply if the serial number or model number has been removed or altered. This warranty is valid only when (1) the equipment is purchased and retained for use within the United States or Canada; (2) the repair of defects is performed by APW Wyott or by an APW Wyott authorized service agency; and (3) all replacement parts are approved APW Wyott parts. This is the only warranty made in connection with the sale of the equipment as specified above and all other expressed, statutory and implied warranties, including without limitation, all implied warranties of merchantability are expressly denied. In no event shall the user be entitled to recover incidental or consequential damages, including but not limited to, damages for inconvenience, rental or replacement equipment, loss of profits, or other commercial loss (all to the extent permitted by law).

### WARRANTY PROCEDURE

If warranty service is needed on your APW Wyott equipment, follow these steps:

1. Secure the model and serial number from the rating label on your toaster.
2. Consult the enclosed directory, find the service agency nearest you, and call the number listed or the 24-hour toll free service hot line, 1-800-733-2203. If there is not a service agency listed for your area, the parts distributor will provide service for your toaster.
3. To order parts, consult the enclosed directory. The parts distributor is listed at the beginning of each state listing. The parts distributors have a complete stock of parts for your toaster.

24 Hour Toll Free Service Hot Line



1-800-733-2203

[www.APWwyott.com](http://www.APWwyott.com)