



**INSTALLATION
AND
OPERATING
INSTRUCTIONS**

DRYWELL

MODEL: TBDIDW-3

! NOTICE: This product is intended for commercial use only. Not for household use. **!**

! WARNING: Improper installation, operation, service or maintenance can cause property damage, injury or death. Read and understand these instructions thoroughly before positioning, installing, maintaining or servicing this equipment. **!**

IMPORTANT FOR FUTURE REFERENCE

Please complete this information and retain this manual for the life of the equipment. For Warranty Service and/or Parts, this information is required.

_____ _____ _____
Model Number Serial Number Date Purchased



ANSI/NSF4

P/N 4877255 10-06

APW WYOTT Foodservice Equipment Company
P.O. Box 1829
Cheyenne, WY 82003

+1 (307) 634-5801 Phone
+1 (307) 637-8071 FAX

+1 (800) 752-0863 Toll Free
Www.apwwyott.com

TABLE OF CONTENTS:

ITEM	PAGE	ITEM	PAGE
Safety Precautions	2	Cleaning	6
Owners Information	3	Troubleshooting	6
Warranty Information	3	Preventative Maintenance Schedule	7
Specifications	3	Wiring Diagram	7
Installation Instructions	3	Parts List w/Exploded View	7
Operation	4	Warranty	8

Congratulations on your purchase of APW Wyott commercial cooking or refrigeration equipment. APW Wyott takes pride in the design and quality of our products. When used as intended and with proper care and maintenance, you will experience years of reliable operation from this equipment. To ensure best results, it is important that you read and follow the instructions in this manual carefully.

IMMEDIATELY INSPECT FOR SHIPPING DAMAGE All containers should be examined for damage before and during unloading. The freight carrier has assumed responsibility for its safe transit and delivery. If equipment is received damaged, either apparent or concealed, a claim must be made with the delivering carrier.



A) Apparent damage or loss must be noted on the freight bill at the time of delivery. It must then be signed by the carrier representative (Driver). If this is not done, the carrier may refuse the claim. The carrier can supply the necessary forms.



B) Concealed damage or loss if not apparent until after equipment is uncrated, a request for inspection must be made to the carrier within 15 days. The carrier should arrange an inspection. Be certain to hold all contents and packaging material.

Installation and start-up should be performed by a qualified installer who thoroughly read, understands and follows these instruction.



If you have questions concerning the installation, operation, maintenance or service of this product, write Technical Service Department APW Wyott Foodservice Equipment Company, P.O. Box 1829, Cheyenne, WY 82003.

SAFETY PRECAUTIONS

 **DANGER:** This symbol warns of imminent hazard which will result in serious injury or death. 

 **WARNING:** This symbol refers to a potential hazard or unsafe practice, which could result in serious injury or death. 

 **CAUTION:** This symbol refers to a potential hazard or unsafe practice, which may result in minor or moderate injury or product or property damage. 

 **NOTICE:** This symbol refers to information that needs special attention or must be fully understood even though not dangerous. 

CAUTION: APW Wyott equipment is designed, built, and sold for commercial use and should be operated by trained personnel only. Clearly post all CAUTIONS, WARNINGS and OPERATING INSTRUCTIONS near each unit to insure proper operation and to reduce the chance of personal injury and/or equipment damage. This product is used for the hot holding of food products only.



WARNING: Always disconnect power before servicing the unit. Surfaces will remain hot after power has been turned off. Allow unit to cool before cleaning or servicing. Never clean the unit by immersing it in water. The unit is not protected against water jets; DO NOT CLEAN DRYWELL WITH A WATER JET. Always clean equipment properly before first use.



OWNER'S INFORMATION

General Information:

1. Always clean equipment thoroughly before first use. (See general cleaning instructions).
2. Check rating label for your model designation and electrical rating.
3. For best results, use stainless steel countertops.

General Operation Instructions:

1. All foodservice equipment should be operated by trained personnel.
 2. Do not allow your customers to come in contact with any surface labeled "CAUTION HOT".
- Never touch Drywell platen or fins while operating.

WARRANTY INFORMATION

Reliability Backed By APW Wyott's Warranty:

All APW Wyott Drywells are backed by a one year parts and labor warranty, including On-Site Service calls within 50 miles of authorized service technicians.

Service Information:

Service Hotline (800) 733-2203

SPECIFICATIONS

Dimensions: 38.69" W x 20.15" D x 9.07" H

Electrical Ratings: 3825W, 208V, 18.4A (Single Phase), Direct wire to breaker.

Power Cord: The Drywell is designed to be hard wired to respective breaker.

Shipping Weight: TBDIDW-3 170 lbs. (77.1)

INSTALLATION INSTRUCTIONS

If the carton appears damaged, or damage is discovered once the carton is opened, stop immediately and contact the freight company to file a damage claim.

1. Remove all external packaging that is protecting unit.
2. Remove unit from shipping container while in packaged position. The unit can be lifted and oriented where wells are facing up. Note: Do not bend or scratch top frame perimeter and cross supports.
3. Remove all internal packaging to the unit.
4. Visually inspect all external and internal portions of unit for damage.

- Wipe down the exterior of the unit using a cloth with warm water. Do not use abrasive pads or cleaners as they will damage the stainless steel frame, anodized aluminum platen and aluminum well and fins. NOTE: DO NOT USE CLEANERS OF ANY KIND ON THE ANODIZED PLATES.
- Place unit in operating location. Make sure that the operating location is in an area where the ambient temperature is held constant (minimum 70°F). Please avoid areas such as near exhaust fans and air conditioning ducts.

OPERATION

- The controls that operate the heaters are located on the front right side of the existing steam well.
- The On/Off switch is used to turn the unit on or off. Once the unit is turned on the platen and well surfaces will reach 290°F.
- The control display (square keypad) is used to control the three heated zones of the Drywell. The control settings allow for a left, center and right zone control. The temperature setting is set to factory defaults (See control operation below).
- Note:** Before touching the On/Off button, please read the following statements: The unit's external surface temperatures will be hot. Use caution when touching these areas to avoid injury.
- The Drywell should always have all pans in place to ensure efficient heating to food product. This unit has three heating zones that are completely independent of each other. As you face the assembly line the zones are broken into a left, center and right; or zones one, two and three respectively.

Caution Warning

External Surface Temperatures Could Cause Severe Burns.

Do not touch platen, well or fins once power is applied

Control Operation

This Drywell has 3 heating zones. Each zone runs front to back. The three zones are then operated independently left to right with a left, center and right zone.

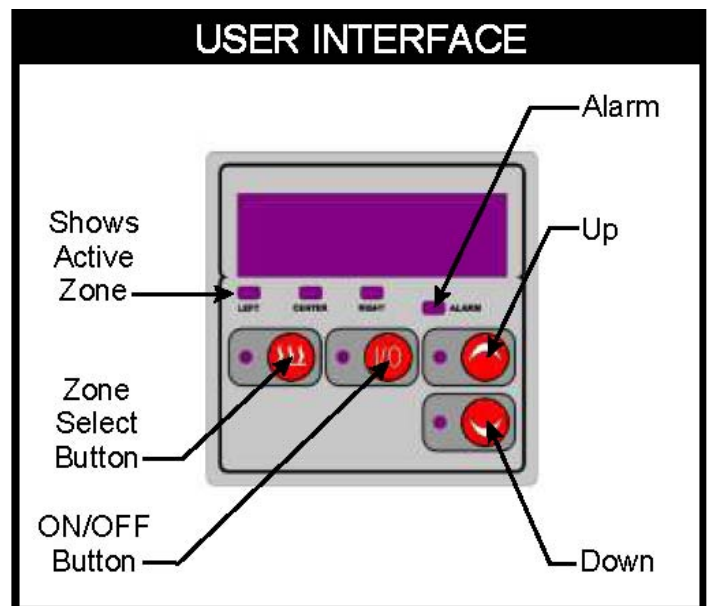

There are 4 keys allowing user to turn unit on and off; select which zone is active and allow service to increment or decrement settings if needed. The LED's labeled LEFT, CENTER and RIGHT will show which zone is actively displayed. The ALARM LED when lit will notify user that there is a problem and service is needed.

OPERATING MODES

Display

Set point temperature is displayed as 290°F. The acceptable Drywell range is $\pm 5^\circ\text{F}$.
The factory default is 290°F.

Preheat Mode

When the breaker is switched on and power is applied to the Drywell the display will run through its normal boot up routine and checks.

The unit will then display OFF.

Once the I/O (On/Off) button is pressed the unit will then turn on.

The current temperature will be displayed.

Ready Mode

The unit is ready when the temperature on the display reads $290^\circ\text{F} \pm 5^\circ\text{F}$. **Remember:** You can press the zone select button to view temperatures of all zones.

Special Features

Alarms and Warnings Alarms cause the Alarm LED to come on and the buzzer to sound (all outputs shut off).

Warnings cause the Alarm LED to blink and the buzzer to sound (unit remains useable). Appropriate message is scrolled on display. Pressing the Down key Mutes the buzzer (until a new alarm/warning), but does not clear

alarm/warning.

Alarms/Warnings are cleared automatically when the situation is resolved.

Probe Warnings/Alarm Occurs when a temperature probe fails open or short.

Display scrolls PROBE FAILURE -CALL FOR SERVICE

In Off mode, the corresponding Zone (1, 2, or 3) LED also blinks.

* In other modes, LED are used normally, but if a zone "in error" is selected, the above message scrolls instead of the zone's temperature.

Output associated to defective probe is driven at theoretical output level (i.e. set point duty cycle) allowing unit to temporarily continue operation.

Overheat Alarms

Occurs when a temperature probe reading exceeds 375°F .

Display scrolls ZONE OVERHEAT-CALL FOR SERVICE

In Off mode, the corresponding Zone (1, 2, or 3) LED blinks Operation cannot continue while temperature remains high

CLEANING

Procedure Frequency: Daily at Closing

Supplies:

Soap and Warm Water
Food Service Towels



Protective Fry Gloves



Angled Grill Tool

Procedure (Daily):

 **WARNING:** DO NOT immerse Drywell or platin in water. 

 **WARNING:** DO NOT move Drywell from production line. 

 **WARNING:** DO NOT touch Drywell platen surfaces without wearing a protective fry glove. 

 **WARNING:** DO NOT use abrasive pads or cleaning solutions (i.e. Sizzle). 

1. Turn off Drywell and allow time for cooling.
NOTE: DO NOT add ice or water to the Drywell surface to accelerate cooling, this can damage the platen and heating fins. Allow time for platen to cool.
2. Dampen a cloth with soapy water.
3. Apply the damp cloth to the platens and stainless steel trim, but do not pour soapy water onto platen surface
NOTE: Typical cleaning should require small amount of non-abrasive soap but the amount used will vary depending on soil level. DO NOT use "SIZZLE" grill cleaner. Sizzle will damage the finish of the aluminum.
4. Apply adequate pressure to the damp cloth to remove soil; hard scrubbing is not necessary.
5. Wet a clean towel and ring out the excess water in sink or bucket.
6. Wipe platen surface with damp towel to remove left over soap and soil from platen surface and stainless steel trim.
7. Rinse the towel and wipe the platen surface again until platens are absolutely clean.

TROUBLESHOOTING

Always ask and check the following:

Not getting power:

1. Is the unit connected to a live power source of the proper voltage?
2. Check the rating label. Is the unit connected to the correct power source?
3. Check the circuit breaker.
4. power switch "ON" and led displaying information?
5. If the above checks out, and you still have problems, call your local service agent.

PREVENTATIVE MAINTENANCE SCHEDULE

Please follow the cleaning section for the daily preventative maintenance schedule.

- ➔ DO NOT USE ABRASIVES OR CLEANING SOLUTIONS ON THIS APPLIANCE.
- ➔ DO NOT IMMERSE THE DRYWELL IN WATER.
- ➔ DO NOT ATTEMPT TO MAINTENANCE, SERVICE OR CLEAN THE UNDERSIDE OR ELECTRICAL BOX TO THE DRYWELL.

WIRING DIAGRAM

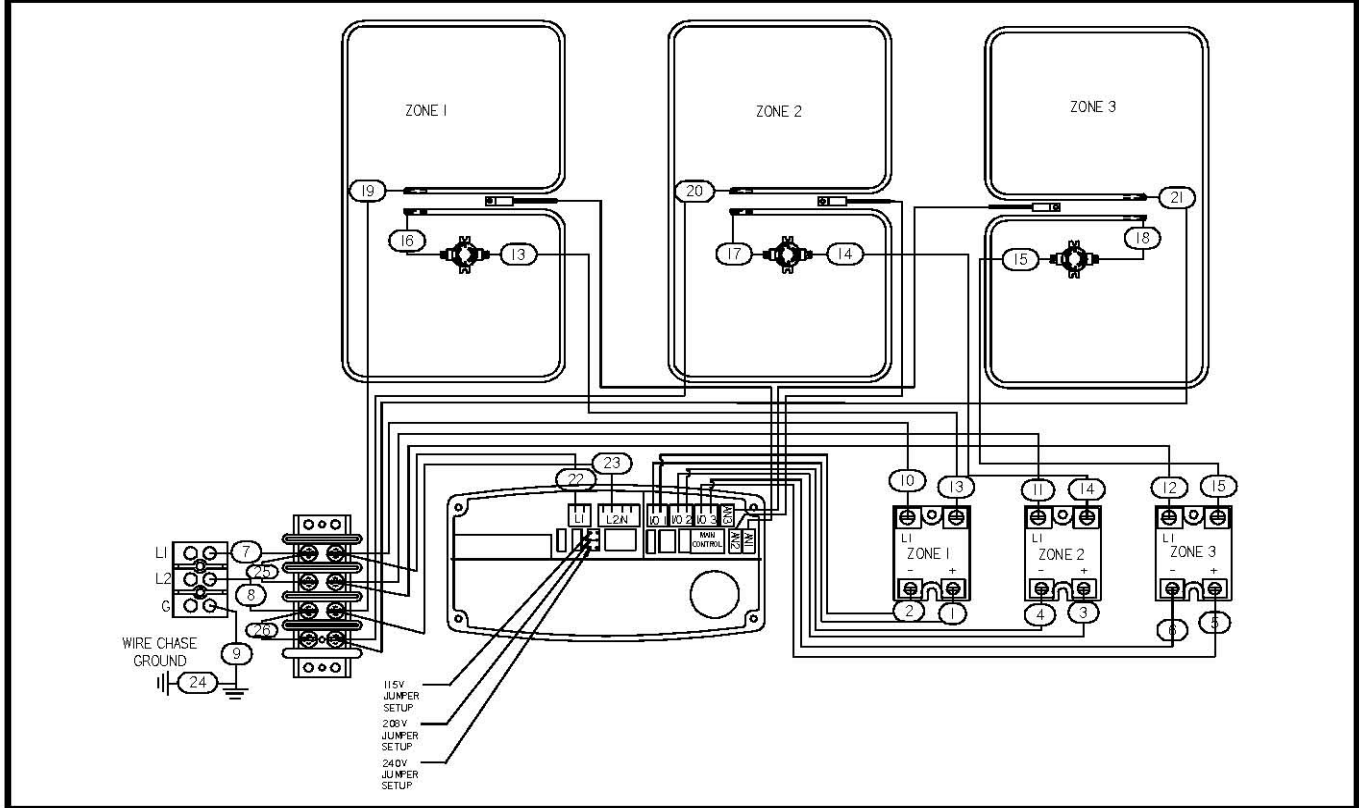

PARTS LIST W/EXPLODED VIEW

Item	Part No.	Description	Quan.
1	4877234	Heating Element	3
2	4877223	RTD Temperature Probe	3
3	4877224	High Limit Switch	3
4	4877233	Controller Cable	1
5	496000002	Display / Keypad	1
6	1335010	Controller, Gecko ECM-3	1
7	782162	Solid State Relay	3

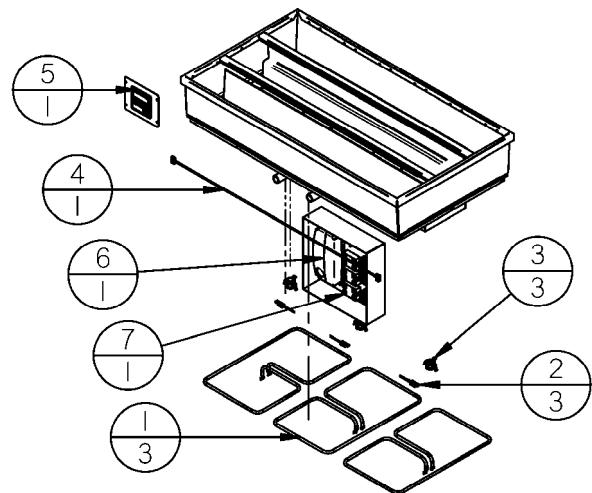

APW WYOTT EQUIPMENT LIMITED WARRANTY

APW Wyott Foodservice Equipment Company warrants its equipment against defects in materials and workmanship, subject to the following conditions:

This warranty applies to the original owner only and is not assignable.

Should any product fail to function in its intended manner under normal use within the limits defined in this warranty, at the option of APW Wyott such product will be repaired or replaced by APW Wyott or its Authorized Service Agency. APW Wyott will only be responsible for charges incurred or service performed by its Authorized Service Agencies. The use of other than APW Wyott Authorized Service Agencies will void this warranty and APW Wyott will not be responsible for such work or any charges associated with same. The closest APW Wyott Authorized Service Agent must be used.

This warranty covers products shipped into the 48 contiguous United States, Hawaii, metropolitan areas of Alaska and Canada. There will be no labor coverage for equipment located on any island not connected by roadway to the mainland.

Warranty coverage on products used outside the 48 contiguous United States, Hawaii, and metropolitan areas of Alaska and Canada may vary. Contact the international APW Wyott distributor, dealer, or service agency for details.

Time Period

One year for parts and one year for labor, effective from the date of purchase by the original owner. The Authorized Service Agency may, at their option, require proof of purchase. Parts replaced under this warranty are warranted for the un-expired portion of the original product warranty only.

Exceptions

- ***Gas/Electric Cookline:** Models GCB, GCRB, GF, GGM, GGT, CHP-H, EF, EG, EHP. Three (3) Year Warranty on all component parts, except switches and thermostats. (2 additional years on parts only. No labor on second or third year.)
- ***Broiler Briquettes, Rock Grates, Cooking Grates, Burner Shields, Fireboxes:** 90 Day Material Only. No Labor.
- ***Heat Strips:** Models FD, FDL, FDD, FDDL. Two (2) Year Warranty on element only. No labor second year.
- ***Glass Windows, Doors, Seals, Rubber Seals, Light Bulbs:** 90 Day Material Only. No Labor.

In all cases, parts covered by extended warranty will be shipped FOB the factory after the first year.

Portable Carry In Products

Equipment weighing over 70 pounds or permanently installed will be serviced on-site as per the terms of this warranty. Equipment weighing 70 pounds or under, and which is not permanently installed, i.e. with cord and plug, is considered portable and is subject to the following warranty handling limitations. If portable equipment fails to operate in its intended manner on the first day of connection, or use, at APW Wyott's option or its Authorized Service Agency, it will be serviced on site or replaced.

From day two through the conclusion of this warranty period, portable units must be taken to or sent prepaid to the APW Wyott Authorized Service Agency for in-warranty repairs. No mileage or travel charges are allowed on portable units after the first day of use. If the customer wants on-site service, they may receive same by paying the travel and mileage charges. Exceptions to this rule: (1) countertop warmers and cookers, which are covered under the Enhanced Warranty Program, and (2) toasters or rollergrills which have in store service.

Exclusions

The following conditions are not covered by warranty:

- *Equipment failure relating to improper installation, improper utility connection or supply and problems due to ventilation.
- *Equipment that has not been properly maintained, calibration of controls, adjustments, damage from improper cleaning and water damage to controls.
- *Equipment that has not been used in an appropriate manner, or has been subject to misuse or misapplication, neglect, abuse, accident, alteration, negligence, damage during transit, delivery or installation, fire, flood, riot or act of god.
- *Equipment that has the model number or serial number removed or altered.

If the equipment has been changed, altered, modified or repaired by other than an Authorized Service Agency during or after the warranty period, then the manufacturer shall not be liable for any damages to any person or to any property, which may result from the use of the equipment thereafter.

This warranty does not cover services performed at overtime or premium labor rates. Should service be required at times which normally involve overtime or premium labor rates, the owner shall be charged for the difference between normal service rates and such premium rates. APW Wyott does not assume any liability for extended delays in replacing or repairing any items beyond its control.

In all cases, the use of other than APW Wyott Authorized OEM Replacement Parts will void this warranty.

This equipment is intended for commercial use only. Warranty is void if equipment is installed in other than commercial application.

Water Quality Requirements

Water supply intended for a unit that has in excess of 3.0 grains of hardness per gallon (GPG) must be treated or softened before being used. Water containing over 3.0 GPG will decrease the efficiency and reduce the operation life of the unit.

Note: Product failure caused by liming or sediment buildup is not covered under warranty.

"THE FOREGOING WARRANTY IS IN LIEU OF ANY AND ALL OTHER WARRANTIES EXPRESSED OR IMPLIED INCLUDING ANY IMPLIED WARRANTY OF MERCHANTABILITY OR FITNESS FOR PARTICULAR PURPOSES AND CONSTITUTES THE ENTIRE LIABILITY OF APW WYOTT. IN NO EVENT DOES THE LIMITED WARRANTY EXTEND BEYOND THE TERMS STATED HEREIN."

9/05