



# D W C 1 3

## W A R M E R C A B I N E T

### INSTALLATION INSTRUCTIONS

1. UNPACK. There should be one cabinet and two shelves.
2. Check for loose or damaged parts.
3. Plug the unit into a 120V outlet.
4. Check to see that the light turns on and that the unit heats up.

### OPERATING INSTRUCTIONS

1. Turn on unit.
2. Set dial to "5" (see "KNOB SETTING" diagram).

#### KNOB SETTING:

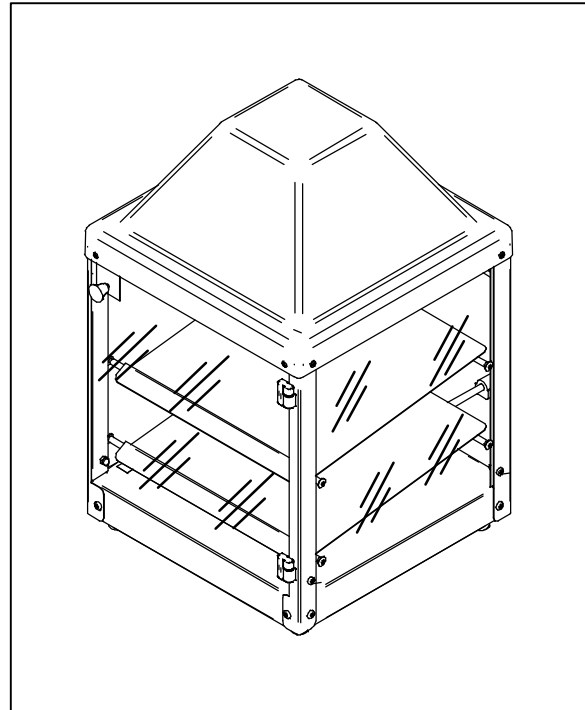
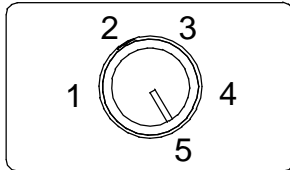

3. Let warm up for 1 hour.
4. For less heat, turn it down (e.g. to "4").
5. When done, turn off unit.

### DAILY CLEANING INSTRUCTIONS

1. Turn unit off and unplug the unit from the power outlet.
2. Doors may be removed for cleaning.
3. Clean the cabinet with soapy water and a soft cloth. **Do not use chemicals such as ammonia, alcohol, or chlorine to clean the cabinet.** The door and sides are made of plastic, and these chemicals will cause cracking. The plastic sides are easily scratched, so be sure to use something soft to wash them.
4. **DO NOT IMMERSE CABINET IN WATER. DO NOT JET SPRAY CABINET. DO NOT PUT CABINET IN A DISHWASHER.**
5. The shelves are stainless steel, and may be machine washed.

## **SPECIFICATIONS**

POWER: 120V, 205W, 60HZ

OVERALL DIMENSIONS: 12 <sup>3</sup>/<sub>4</sub> Wide x 12 <sup>3</sup>/<sub>4</sub> Deep x 20 <sup>1</sup>/<sub>2</sub> High

INSIDE DIMENSIONS: 12" Wide x 12 <sup>1</sup>/<sub>4</sub>" Deep x 11 <sup>5</sup>/<sub>8</sub>" High

CORDSET: NEMA 5-15P PLUG, 5 FT, 3 GROUNDED WIRE CORD

SHIPPING WEIGHT: 25 lbs.

APPROVALS: UL listed (Canada & US), UL EPH (NSF 4)

## **SPARE PARTS**

ITEM	DESCRIPTION	PART NUMBER
1	STAINLESS STEEL SHELF	66922
2	ADJUSTMENT KNOB (0-5)	89499
3	LIGHT BULB, COATED (120V 40W)	75916
4	DOOR KNOB	89165
4A	SCREW FOR DOOR KNOB (NEED 1/EA)	89029
5	DOOR	66931
6	STRIKER PLATE (FOR DOOR MAGNET)	66923
7	DOOR HINGE	66937
7A	SCREW FOR DOOR HINGE (NEED 2/EA)	88984
7B	SCREW FOR FRAME HINGE (NEED 2/EA)	88856
8	SHELF ROD	66933
8A	SHELF ROD SCREWS	88993
9	DOOR MAGNET	66936
9A	SCREW FOR DOOR MAGNET (NEED 2/EA)	88854