



**INSTALLATION  
AND  
OPERATING  
INSTRUCTIONS**

**Models: FDC, FDDC, FDLC & FDDL**

**CERAMIC OVERHEAD FOODWARMERS**

**INTENDED FOR OTHER THAN HOUSEHOLD USE**

**RETAIN THIS MANUAL FOR FUTURE REFERENCE  
UNIT MUST BE KEPT CLEAR OF COMBUSTIBLES AT ALL TIMES**



**FOR YOUR SAFETY:** Do not store or use gasoline or other flammable vapors and liquids in the vicinity of this or any other appliance.



**WARNING:** Improper installation, adjustment, alteration, service or maintenance can cause property damage, injury or death. Read the Installation, Operating and Maintenance Instructions thoroughly before installing or servicing this equipment.



Initial heating of unit may generate smoke or fumes and must be done in a well ventilated area. Overexposure to smoke or fumes may cause nausea or dizziness.

This equipment has been engineered to provide you with year-round dependable service when used according to the instructions in this manual and standard commercial kitchen practices.



**\* NOTE: ONLY SINGLE UNITS AVAILABLE IN CANADA**

Phone: (214) 421-7366  
Fax: (214) 565-0976  
Toll Free: (800) 527-2100  
Website: [www.apwwyott.com](http://www.apwwyott.com)  
E-mail: [info@apwwyott.com](mailto:info@apwwyott.com)

P/N 70499001 Rev. 9/05

**APW WYOTT**  
729 Third Avenue  
Dallas, TX 75226

# TABLE OF CONTENTS

SECTION	ITEM	PAGE
1	General Information _____	2
2	Electrical Requirements _____	2
3	Electrical Specifications _____	3
4	Overall Dimensions _____	5
5	Installation _____	6
6	Operation _____	6
7	Cleaning _____	6
8	Troubleshooting _____	6
9	Wiring Diagrams _____	7
	A. FDC-120V _____	7
	B. FDC-208/240 _____	7
	C. FDLC-120V _____	8
	D. FDLC-208/240V _____	8
	E. FDLC-120V w/Fuse _____	9
	F. FDDC-120V _____	9
	G. FDDC-208/240V _____	10
	H. FDDL-120V _____	10
	I. FDDL-208/240V _____	11
	J. FDDL-208/240 w/Fuse _____	11
	K. Element Configuration - Chart "A" _____	12
10	Parts List & Exploded View _____	13
11	Warranty _____	16

## 1. GENERAL INFORMATION

- A. APW Wyott Overhead Foodwarmers are constructed from high quality stainless steel and available in lengths from 18" to 72". Utilizing a ceramic heating element with a reflector, these units give uniform heat over the entire holding surface.

## 2. ELECTRICAL REQUIREMENTS

- A. Single phase operation at 120, 208, and 240 volts.  
B. Field-wired units provided with ½" conduit knockout and terminal blocks easily accessed through control box access plate. For supply connections, use minimum no. 14 AWG copper wires suitable for at least 90°C.

### 3. ELECTRICAL SPECIFICATIONS

STANDARD CERAMIC OVERHEADS ROCKER SWITCH CONTROL												
MODEL	WATTS		VOLTS - RATINGS CIR-1					VOLTS - RATINGS CIR-2				
	CIR-1	CIR-2	120	208	120/208	240	120/240	120	208	120/208	240	120/240
FDC-18	500	~	4.2	2.4	~	2.1	~	~	~	~	~	~
FDC-18	700	~	5.8	3.4	~	2.9	~	~	~	~	~	~
FDLC-18	580	~	4.8	~	3.1	~	2.8	~	~	~	~	~
FDLC-18	780	~	6.5	~	4.0	~	3.6	~	~	~	~	~
FDDC-18	500	500	4.2	2.4	~	2.1	~	4.2	2.4	~	2.1	~
FDDC-18	700	700	5.8	3.4	~	2.9	~	5.8	3.4	~	2.9	~
FDDL-18	500	580	4.2	2.4	~	2.1	~	4.8	~	3.1	~	2.8
FDDL-18	700	780	5.8	3.4	~	2.9	~	6.5	~	4.0	~	3.6
FDC-24	700	~	5.8	3.4	~	2.9	~	~	~	~	~	~
FDC-24	800	~	6.7	3.8	~	3.3	~	~	~	~	~	~
FDLC-24	780	~	6.5	~	4.0	~	3.6	~	~	~	~	~
FDLC-24	880	~	7.3	~	4.5	~	4.0	~	~	~	~	~
FDDC-24	700	700	5.8	3.4	~	2.9	~	5.8	3.4	~	2.9	~
FDDC-24	800	800	6.7	3.8	~	3.3	~	6.7	3.8	~	3.3	~
FDDL-24	700	780	5.8	3.4	~	2.9	~	6.5	~	4.0	~	3.6
FDDL-24	800	880	6.7	3.8	~	3.3	~	7.3	~	4.5	~	4.0
FDC-30	850	~	7.1	4.1	~	3.5	~	~	~	~	~	~
FDC-30	1150	~	9.6	5.5	~	4.8	~	~	~	~	~	~
FDLC-30	930	~	7.8	~	4.8	~	4.2	~	~	~	~	~
FDLC-30	1230	~	10.3	~	6.2	~	5.5	~	~	~	~	~
FDDC-30	850	850	7.1	4.1	~	3.5	~	7.1	4.1	~	3.5	~
FDDC-30	1150	1150	9.6	5.5	~	4.8	~	9.6	5.5	~	4.8	~
FDDL-30	850	930	7.1	4.1	~	3.5	~	7.8	~	4.8	~	4.2
FDDL-30	1150	1230	9.6	5.5	~	4.8	~	10.3	~	6.2	~	5.5
FDC-36	1000	~	8.3	4.8	~	4.2	~	~	~	~	~	~
FDC-36	1350	~	11.3	6.5	~	5.6	~	~	~	~	~	~
FDLC-36	1160	~	9.7	~	6.1	~	5.5	~	~	~	~	~
FDLC-36	1510	~	12.6	~	7.8	~	7.0	~	~	~	~	~
FDDC-36	1000	1000	8.3	4.8	~	4.2	~	8.3	4.8	~	4.2	~
FDDC-36	1350	1350	11.3	6.5	~	5.6	~	11.3	6.5	~	5.6	~
FDDL-36	1000	1160	8.3	4.8	~	4.2	~	9.7	~	6.1	~	5.5
FDDL-36	1350	1510	11.3	6.5	~	5.6	~	12.6	~	7.8	~	7.0
FDC-42	1200	~	10.0	5.8	~	5.0	~	~	~	~	~	~
FDC-42	1500	~	12.5	7.2	~	6.3	~	~	~	~	~	~
FDLC-42	1360	~	11.3	~	7.1	~	6.3	~	~	~	~	~
FDLC-42	1660	~	13.8	~	8.5	~	7.6	~	~	~	~	~
FDDC-42	1200	1200	10.0	5.8	~	5.0	~	10.0	5.8	~	5.0	~
FDDC-42	1500	1500	12.5	7.2	~	6.3	~	12.5	7.2	~	6.3	~
FDDL-42	1200	1360	10.0	5.8	~	5.0	~	11.3	~	7.1	~	6.3
FDDL-42	1500	1660	12.5	7.2	~	6.3	~	13.8	~	8.5	~	7.6

**STANDARD CERAMIC OVERHEADS ROCKER SWITCH CONTROL**

MODEL	WATTS		VOLTS - RATINGS CIR-1					VOLTS - RATINGS CIR-2				
	CIR-1	CIR-2	120	208	120/208	240	120/240	120	208	120/208	240	120/240
FDC-48	1500	~	12.5	7.2	~	6.3	~	~	~	~	~	~
FDC-48	2000	~	~	9.6	~	8.3	~	~	~	~	~	~
FDLC-48	1660	~	13.8	~	8.5	~	7.6	~	~	~	~	~
FDLC-48	2160	~	~	~	10.9	~	9.7	~	~	~	~	~
FDDC-48	1500	1500	12.5	7.2	~	6.3	~	12.5	7.2	~	6.3	~
FDDC-48	2000	2000	~	9.6	~	8.3	~	~	9.6	~	8.3	~
FDDL-48	1500	1660	12.5	7.2	~	6.3	~	13.8	~	8.5	~	7.6
FDDL-48	2000	2160	~	9.6	~	8.3	~	~	~	10.9	~	9.7
FDC-54	1500	~	~	7.2	~	6.3	~	~	~	~	~	~
FDC-54	2200	~	~	10.6	~	9.2	~	~	~	~	~	~
FDLC-54	1660	~	~	~	8.5	~	7.6	~	~	~	~	~
FDLC-54	2360	~	~	~	11.9	~	10.5	~	~	~	~	~
FDDC-54	1500	1500	~	7.2	~	6.3	~	~	7.2	~	6.3	~
FDDC-54	2200	2200	~	10.6	~	9.2	~	~	10.6	~	9.2	~
FDDL-54	1500	1660	~	7.2	~	6.3	~	~	~	8.5	~	7.6
FDDL-54	2200	2360	~	10.58	~	9.2	~	~	~	11.6	~	10.5
FDC-60	2000	~	~	9.6	~	8.3	~	~	~	~	~	~
FDC-60	2700	~	~	13.0	~	11.3	~	~	~	~	~	~
FDLC-60	2240	~	~	~	11.6	~	10.3	~	~	~	~	~
FDLC-60	2940	~	~	~	15.0	~	13.3	~	~	~	~	~
FDDC-60	2000	2000	~	9.6	~	8.3	~	~	9.6	~	8.3	~
FDDC-60	2700	2700	~	13.0	~	11.3	~	~	13.0	~	11.3	~
FDDL-60	2000	2240	~	9.6	~	8.3	~	~	~	11.6	~	10.3
FDDL-60	2700	2940	~	12.98	~	11.3	~	~	~	15.0	~	13.3
FDC-66	2000	~	~	9.6	~	8.3	~	~	~	~	~	~
FDC-66	2700	~	~	13.0	~	11.3	~	~	~	~	~	~
FDLC-66	2240	~	~	~	11.6	~	10.3	~	~	~	~	~
FDLC-66	2940	~	~	~	15.0	~	13.3	~	~	~	~	~
FDDC-66	2000	2000	~	9.6	~	8.3	~	~	9.6	~	8.3	~
FDDC-66	2700	2700	~	13.0	~	11.3	~	~	13.0	~	11.3	~
FDDL-66	2000	2240	~	9.6	~	8.3	~	~	~	11.6	~	10.3
FDDL-66	2700	2940	~	12.98	~	11.3	~	~	~	15.0	~	13.3
FDC-72	2000	~	~	9.6	~	8.3	~	~	~	~	~	~
FDC-72	3000	~	~	14.4	~	12.5	~	~	~	~	~	~
FDLC-72	2240	~	~	~	11.6	~	10.3	~	~	~	~	~
FDLC-72	3240	~	~	~	*16.4	~	14.5	~	~	~	~	~
FDDC-72	2000	2000	~	9.6	~	8.3	~	~	9.6	~	8.3	~
FDDC-72	3000	3000	~	14.4	~	12.5	~	~	14.4	~	12.5	~
FDDL-72	2000	2240	~	9.6	~	8.3	~	~	~	11.6	~	10.3
FDDL-72	3000	3240	~	14.42	~	12.5	~	~	~	*16.4	~	14.5

*	REQUIRES 3 AMP FUSE
*	REQUIRES 30 AMP CIRCUIT

**NOTE:** TO AVOID BURNING OR CHARRING OF MATERIALS IN THE SURFACE BELOW THE FOODWARMER USE ONLY ABOVE AN ALL-METAL STRUCTURE SUCH AS A TABLE OR COUNTERTOP. SEE MINIMUM CLEARANCE CHART ABOVE.

REMOTE SWITCHES ARE RECOMMENDED FOR UNDER SHELF MOUNTING. LONGER SWITCH LIFE WILL RESULT FROM COOLER SWITCH MOUNTING LOCATIONS.

**WARNING:** ELECTRICAL SHOCK HAZARD. FAILURE TO FOLLOW THE INSTRUCTIONS IN THIS MANUAL COULD RESULT IN SERIOUS INJURY OR DEATH.

- Electrical Ground is required on this appliance.
- Do not modify the power supply cord plug. If it does not fit into the outlet, have the proper outlet installed by a qualified electrician
- Do not use an extension cord with this appliance.
- Check with a qualified electrician if you are unsure as to whether the appliance is properly grounded.

#### 4. OVERALL DIMENSIONS

##### FDC / FDLC / FDDC / FDDLCL MODELS

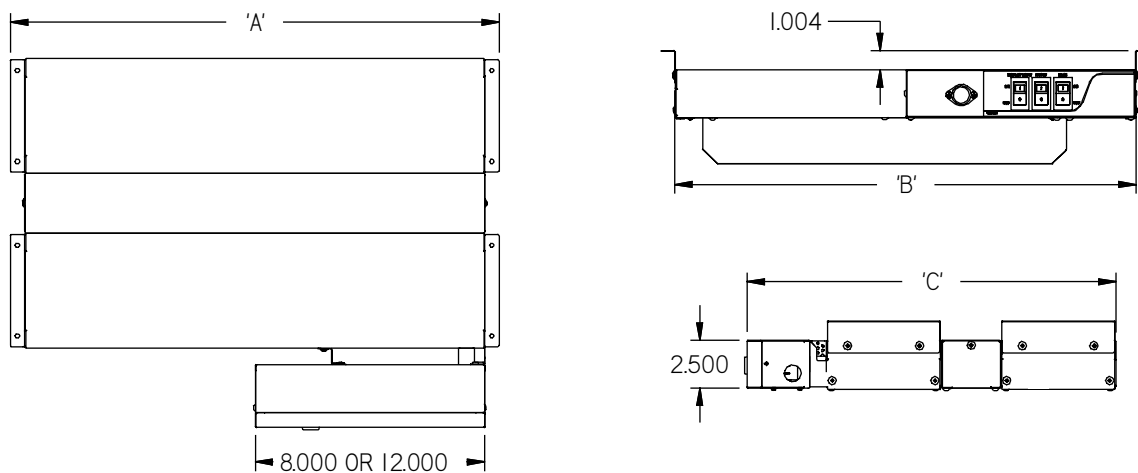

A"	B"	MODEL	C"	MODEL	C"	MODEL	C"
19.554	18.12	FDDC/FDDLCL-18	19.255	FDLC-18	13.255	FDC-18	10.13
25.554	24.12	FDDC/FDDLCL-24	19.255	FDLC-24	13.255	FDC-24	10.13
31.554	30.12	FDDC/FDDLCL-30	19.255	FDLC-30	13.255	FDC-30	10.13
37.554	36.12	FDDC/FDDLCL-36	19.255	FDLC-36	13.255	FDC-36	10.13
43.554	42.12	FDDC/FDDLCL-42	19.255	FDLC-42	13.255	FDC-42	10.13
49.554	48.12	FDDC/FDDLCL-48	19.255	FDLC-48	13.255	FDC-48	10.13
55.554	54.12	FDDC/FDDLCL-54	19.255	FDLC-54	13.255	FDC-54	10.13
61.554	60.12	FDDC/FDDLCL-60	19.255	FDLC-60	13.255	FDC-60	10.13
67.554	66.12	FDDC/FDDLCL-66	19.255	FDLC-66	13.255	FDC-66	10.13
73.554	72.12	FDDC/FDDLCL-72	19.255	FDLC-72	13.255	FDC-72	10.13

## 5. INSTALLATION

- A. Always clean equipment thoroughly before first use (See cleaning instructions).
- B. Provide the following clearances around foodwarmer:
  - 1. Low watt minimum distance to non-combustible surface below: Single = 14", Double = 18".  
High watt minimum distance to non-combustible surface below: Single = 18", Double = 24".
  - 2. Minimum distance to non-combustible side (end) walls = 2"
  - 3. Minimum distance to non-combustible back wall = 2".
  - 4. Minimum distance to non-combustible ceiling = 1"
  - 5. To avoid damage to overhead or surroundings never mount to combustible ceiling. All surrounding back, sides and bottom surfaces to be non-combustible.
- C. Consult foodwarmer rating label for model designation and correct operating voltage and amperage.
- D. Ceiling mounting brackets are provided with each foodwarmer for chain or shelf mounting. Remove brackets from packaging and screws from ends of foodwarmer to attach brackets. Use four #10 screws or studs with locknuts for shelf mounting. For chain mounting, use #14 jack chain and "S" hooks.
- E. Remote switches are recommended. Longer switch life will result from cooler switch mounting locations. Optional stainless steel remote box kits are available. Installation of remote box by service personnel requires ½" conduit, and no. 14 AWG copper wire suitable for at least 90°C. Mount remote box to flat surface with two #10 screws or studs with locknuts. All wires marked as shown on wiring diagram. Whether supplying power to remote or control box remove control box access plate Ref. exploded view item number 29. Fasten supply wires to terminal block marked terminals. To prevent damage to control box components re-install access plate item 29 after making supply connections.
- F. Optional tubular stands are available for permanently mounting foodwarmers to non-combustible countertops.
- G. Optional portable legs are available for foodwarmers for use over non-combustible countertops.

## 6. OPERATION

- A. All foodservice equipment should be operated by trained personnel.
- B. Do not allow your customers to come in contact with any surface labeled "CAUTION HOT".
- C. Switch on unit. Place precooked product under heat source. Maximum heat coverage equivalent to unit length.
- D. Never hold food below 150°F.



## 7. CLEANING

- A. Never clean any electrical unit by immersing it in water.
- B. Never clean any electrical unit using water jets.
- C. Disconnect power before cleaning or servicing units.
- D. Clean unit daily. Use warm, soapy water. Mild cleansers and non-abrasive pads may be used to remove baked-on food.

## 8. TROUBLESHOOTING

- A. Always ask and check:
  - 1. Is the unit connected to a live power source?
  - 2. Check the circuit breaker.
  - 3. Is power switch on and light illuminating?
  - 4. Check the rating label. Is the unit operating on proper voltage?
- B. If the above checks out, and problems still exist, call an APW Wyott authorized service agency.
- C. All service should be performed by an APW Wyott authorized service agency.

## 9. WIRING DIAGRAMS

### A. FDC-120V WIRING DIAGRAM

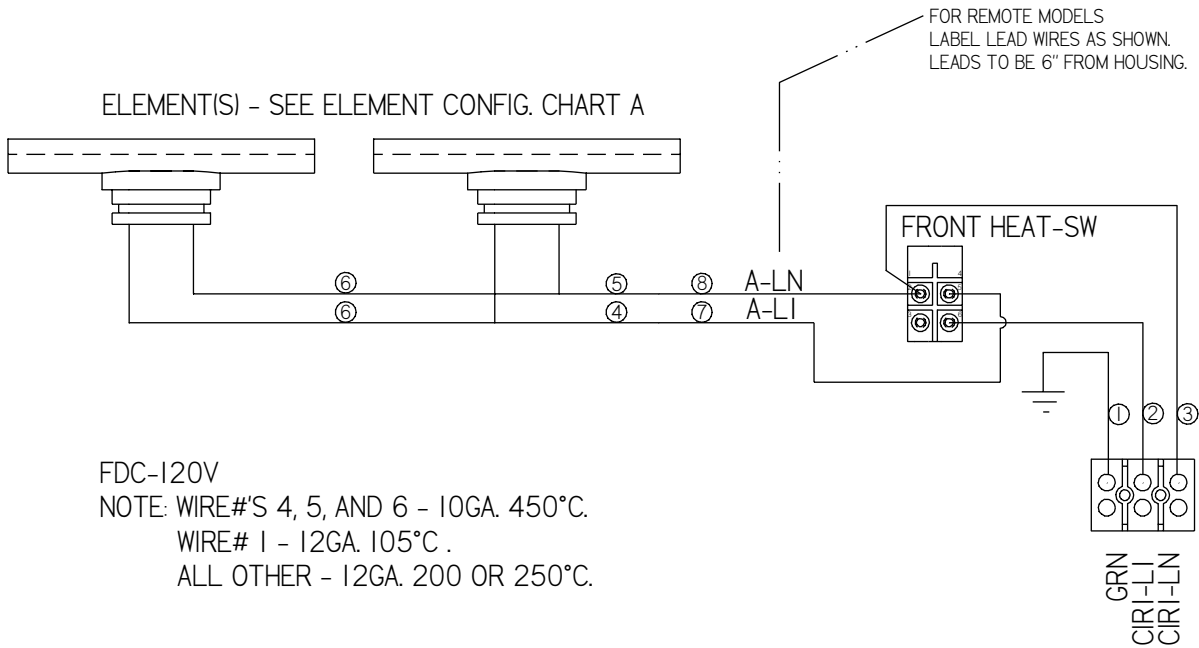

### B. FDC-208/240V WIRING DIAGRAM

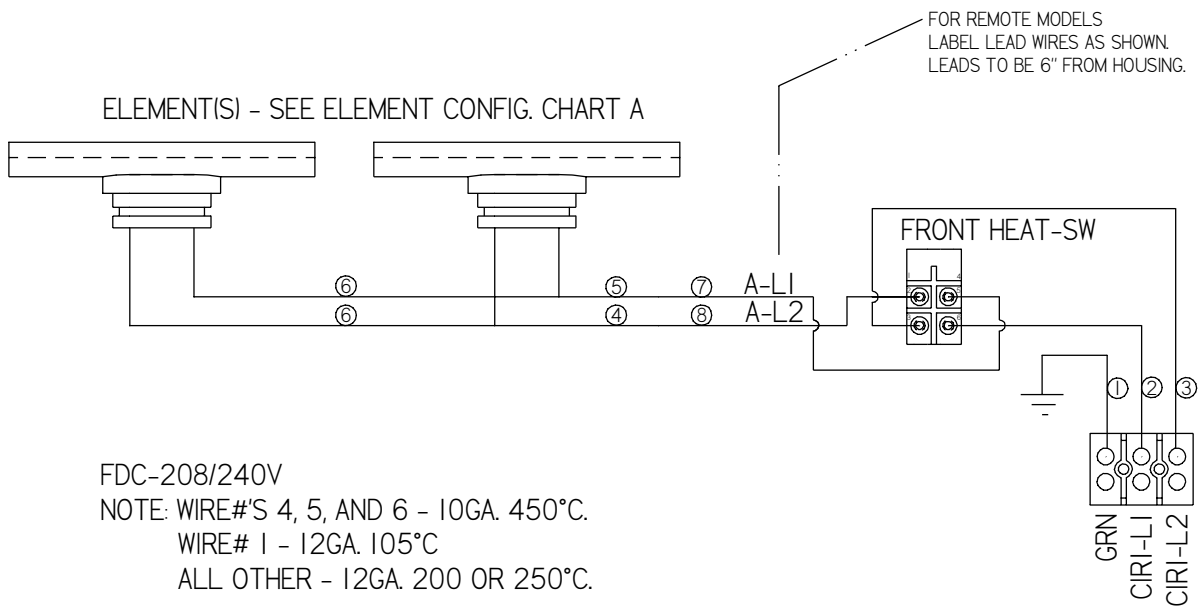

**C.**

**FDLC-120V WIRING DIAGRAM**

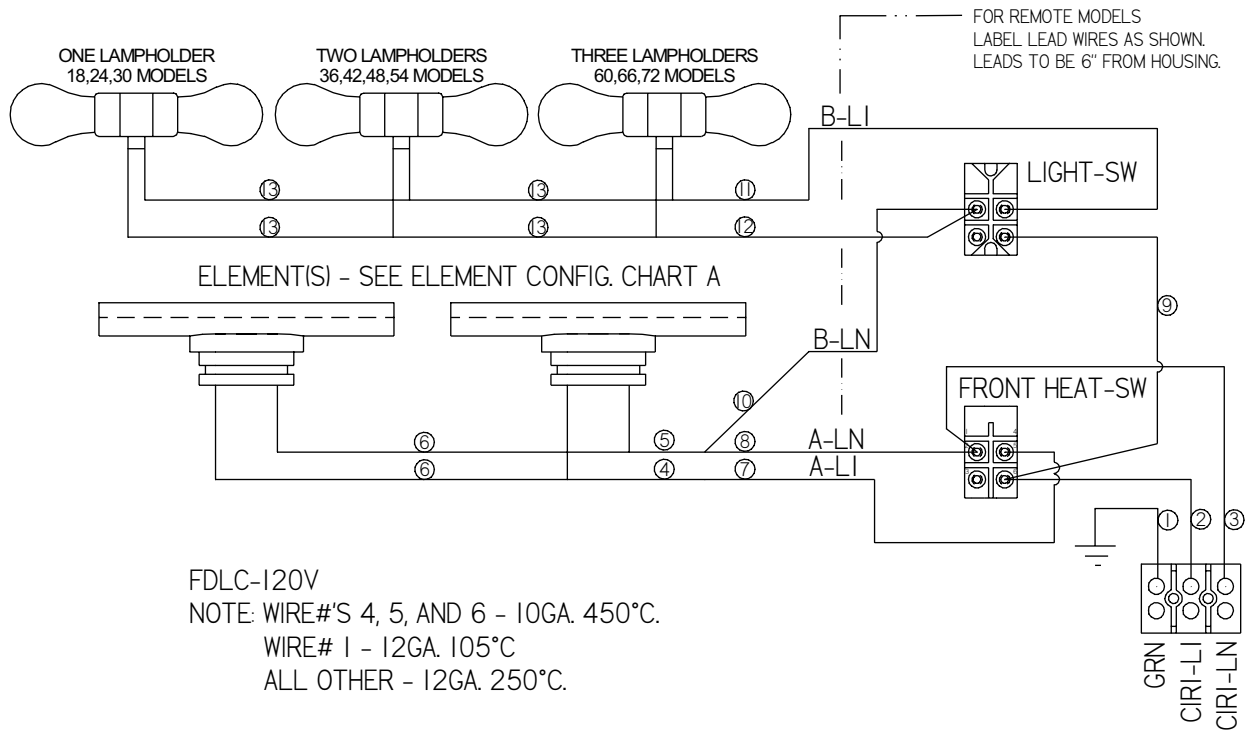

**D.**

**FDLC-208/240V WIRING DIAGRAM**

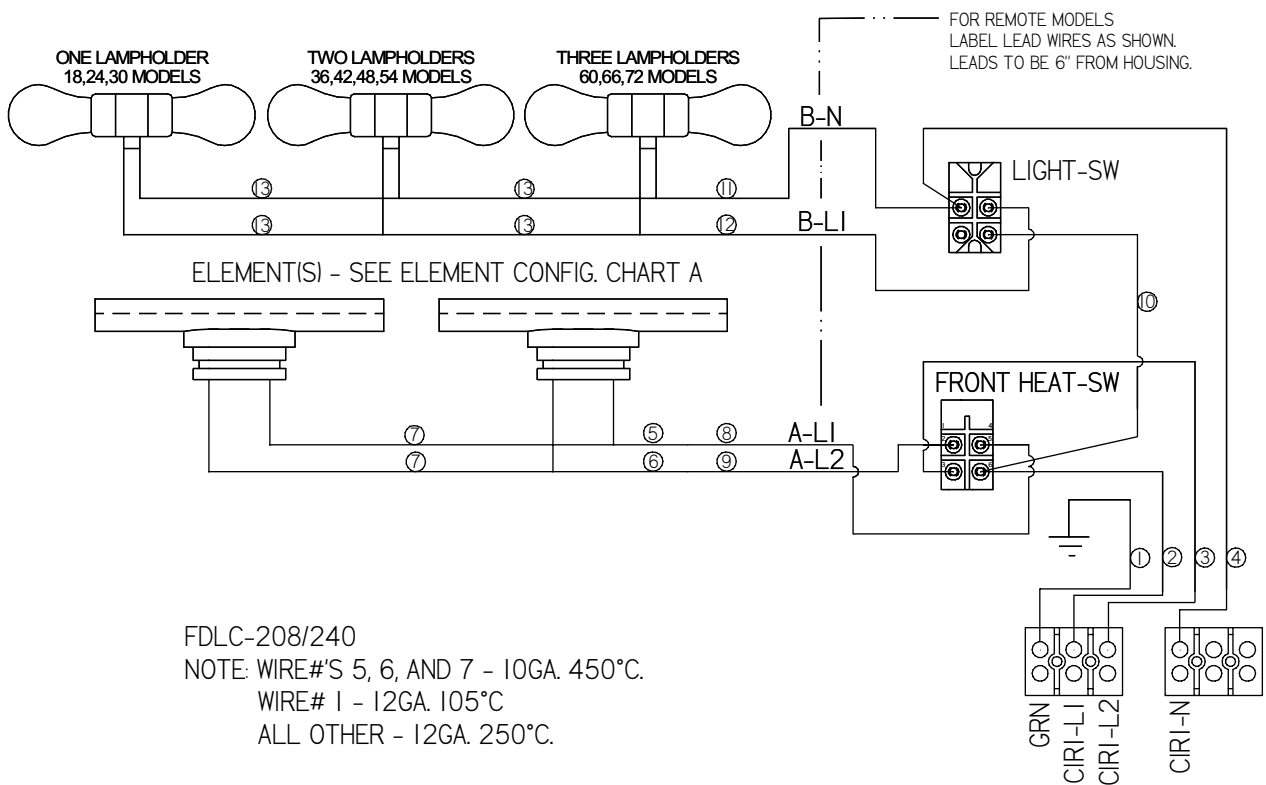

## E. FDLC-208V w/FUSE WIRING DIAGRAM

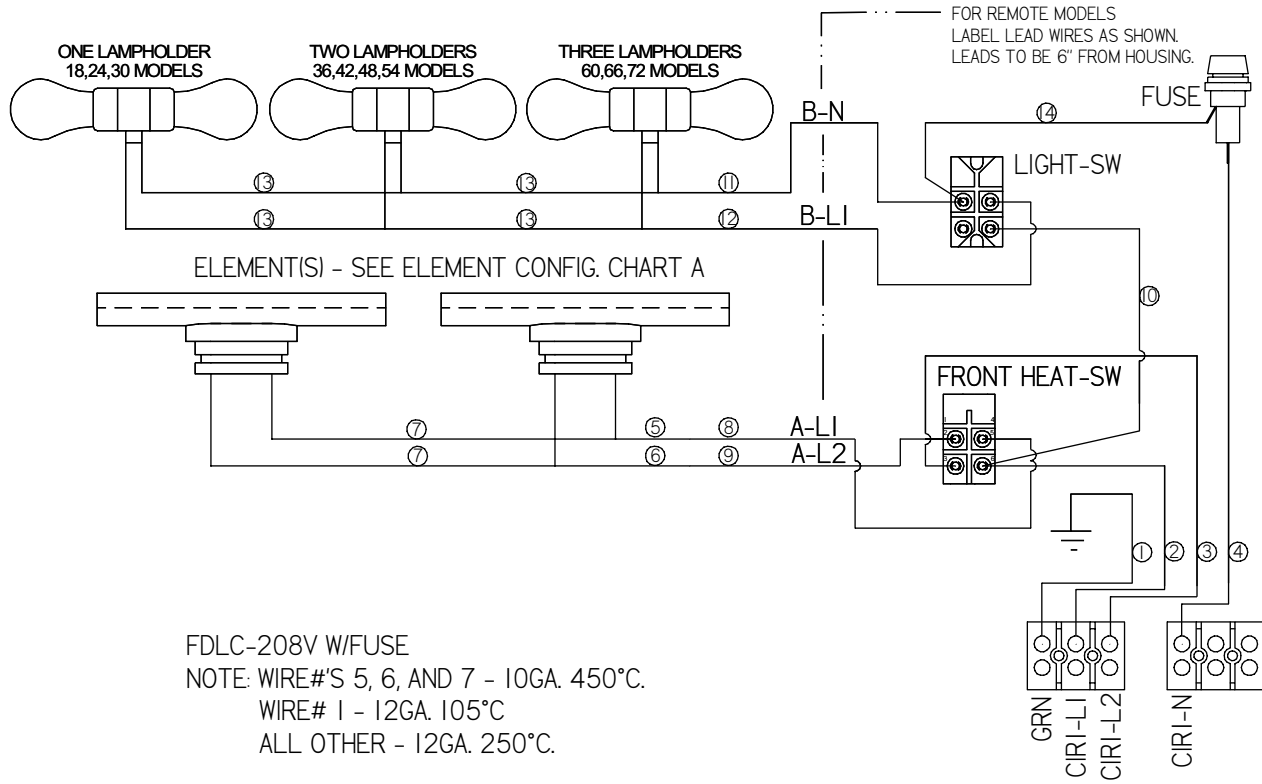

## F. FDDC-120V WIRING DIAGRAM

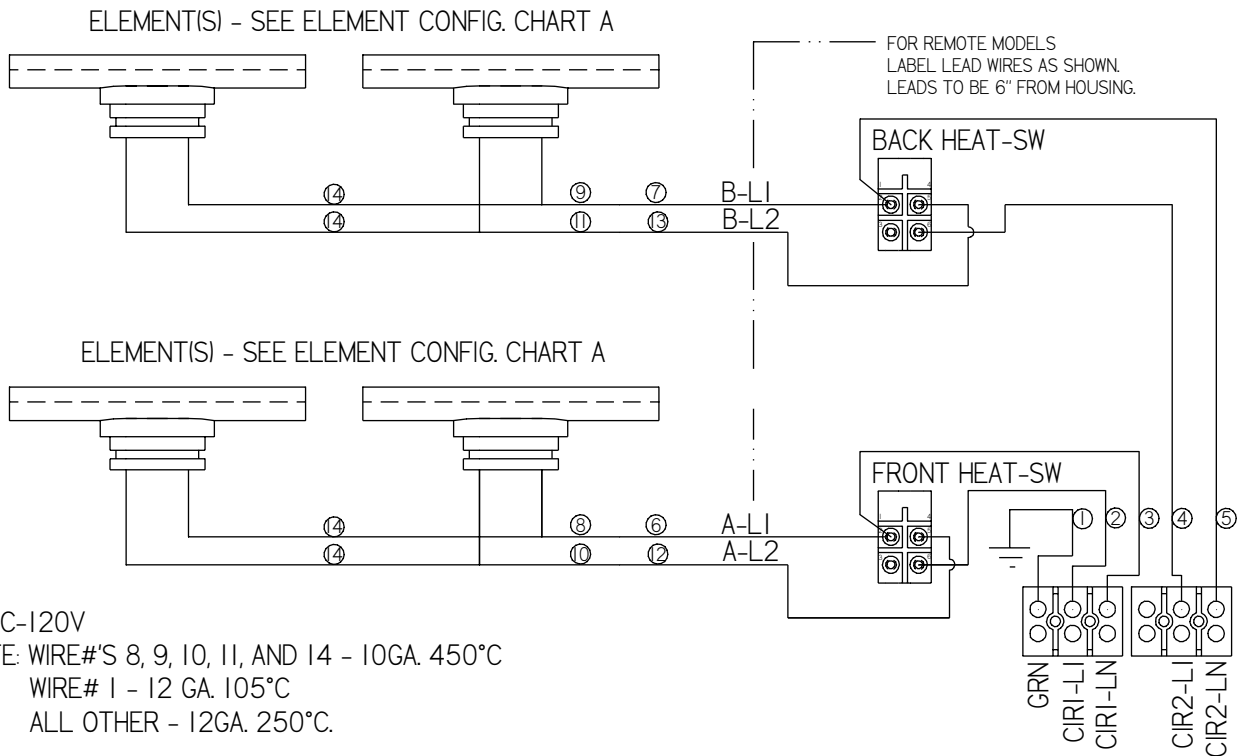



I.

**FDDL-208/240V WIRING DIAGRAM**

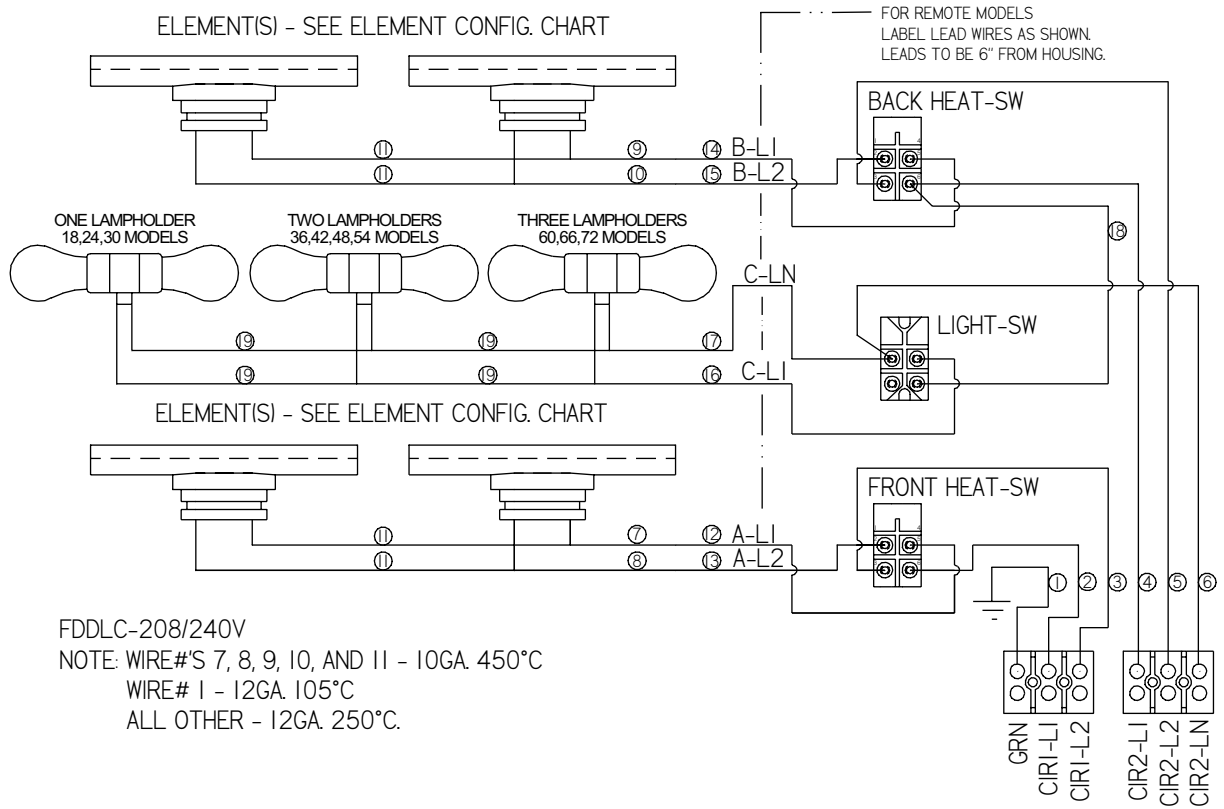

J.

**FDDL-208/240V w/FUSE WIRING DIAGRAM**

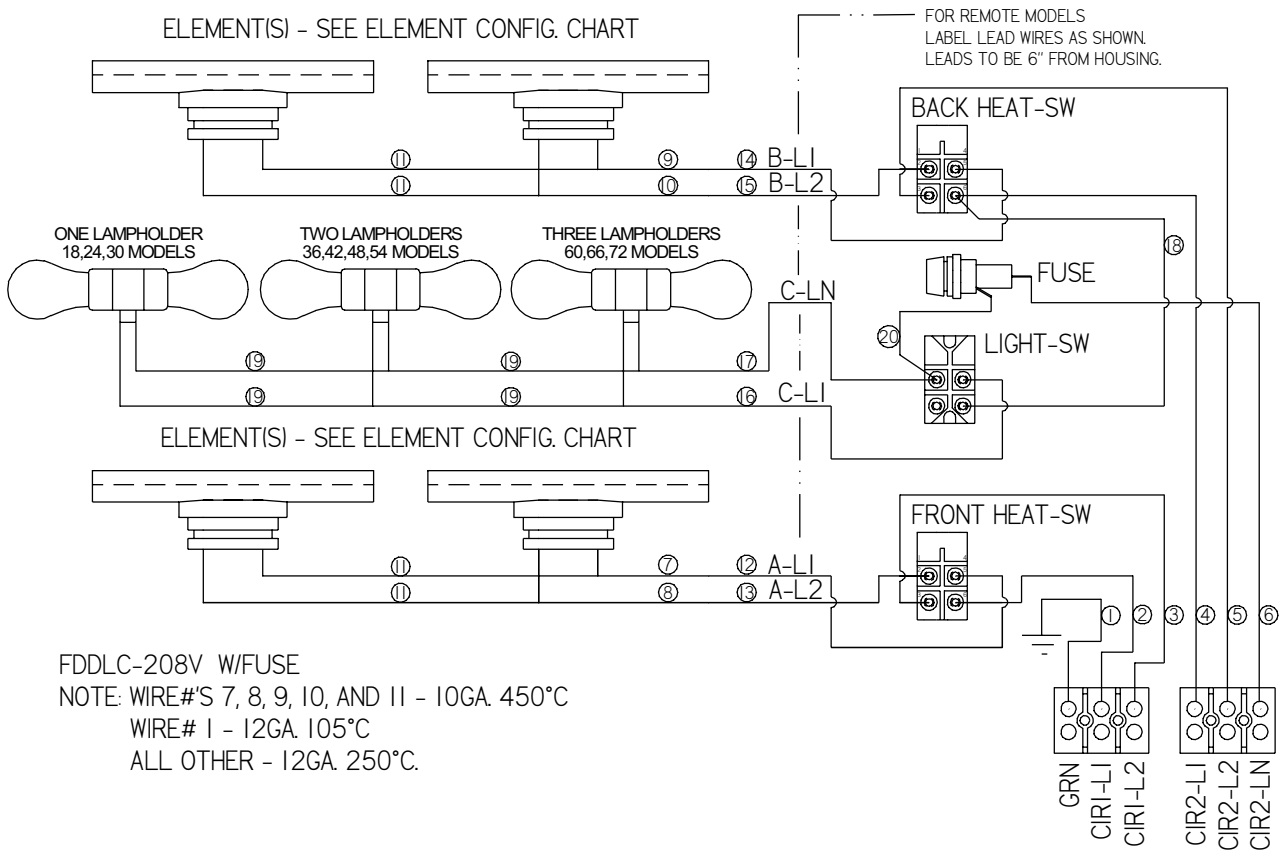

**K.**

**CHART “A” - ELEMENT CONFIGURATION**

MODEL	WATTS	CONFIGURATION	MODEL	WATTS	CONFIGURATION
FDC-18	500	(1F) 500	FDLC-18	580	(1F) 500
	700	(1H) 500 + (1H) 200		780	(1H) 500 + (1H) 200
FDDC-18	1000	(2F) 500	FDDLC-18	1080	(2F) 500
	1400	(2H) 500 + (2H) 200		1480	(2H) 500 + (2H) 200
FDC-24	700	(1F) 500 + (1H) 200	FDLC-24	780	(1F) 500 + (1H) 200
	800	(1H) 500 + (2H) 150		880	(1H) 500 + (2H) 150
FDDC-24	1400	(2F) 500 + (2H) 200	FDDLC-24	1480	(2F) 500 + (2H) 200
	1600	(2H) 500 + (4H) 150		1680	(2H) 500 + (4H) 150
FDC-30	850	(1F) 500 + (1H) 200 + (1H) 150	FDLC-30	930	(1F) 500 + (1H) 200 + (1H) 150
	1150	(2H) 500 + (1H) 150		1230	(2H) 500 + (1H) 150
FDDC-30	1700	(2F) 500 + (2H) 200 + (2H) 150	FDDLC-30	1780	(2F) 500 + (2H) 200 + (2H) 150
	2300	(4H) 500 + (2H) 150		2380	(4H) 500 + (2H) 150
FDC-36	1000	(2F) 500	FDLC-36	1160	(2F) 500
	1350	(2H) 500 + (1H) 200 + (1H) 150		1510	(2H) 500 + (1H) 200 + (1H) 150
FDDC-36	2000	(4F) 500	FDDLC-36	2160	(4F) 500
	2700	(4H) 500 + (2H) 200 + (2H) 150		2860	(4H) 500 + (2H) 200 + (2H) 150
FDC-42	1200	(2F) 500 + (1H) 200	FDLC-42	1360	(2F) 500 + (1H) 200
	1500	(3F) 500		1680	(3F) 500
FDDC-42	2400	(4F) 500 + (2H) 200	FDDLC-42	2560	(4F) 500 + (2H) 200
	3000	(6F) 500		3160	(6F) 500
FDC-48	1500	(3F) 500	FDLC-48	1660	(3F) 500
	2000	(2F) 500 + (2H) 500		2160	(2F) 500 + (2H) 500
FDDC-48	3000	(6F) 500	FDDLC-48	3160	(6F) 500
	4000	(4F) 500 + (4H) 500		4160	(4F) 500 + (4H) 500
FDC-54	1500	(3F) 500	FDLC-54	1660	(3F) 500
	2200	(4F) 500 + (1H) 200		2360	(4F) 500 + (1H) 200
FDDC-54	3000	(6F) 500	FDDLC-54	3160	(6F) 500
	4400	(8F) 500 + (2H) 200		4560	(8F) 500 + (2H) 200
FDC-60	2000	(4F) 500	FDLC-60	2240	(4F) 500
	2700	(2F) 500 + (3H) 500 + (1H) 200		2940	(2F) 500 + (3H) 500 + (1H) 200
FDDC-60	4000	(8F) 500	FDDLC-60	4240	(8F) 500
	5400	(4F) 500 + (6H) 500 + (2H) 200		5640	(4F) 500 + (6H) 500 + (2H) 200
FDC-66	2000	(4F) 500	FDLC-66	2240	(4F) 500
	2700	(4F) 500 + (1H) 500 + (1H) 200		2940	(4F) 500 + (1H) 500 + (1H) 200
FDDC-66	4000	(8F) 500	FDDLC-66	4240	(8F) 500
	5400	(8F) 500 + (2H) 500 + (2H) 200		5640	(8F) 500 + (2H) 500 + (2H) 200
FDC-72	2000	(4F) 500	FDLC-72	2240	(4F) 500
	3000	(4F) 500 + (2H) 500		3240	(4F) 500 + (2H) 500
FDDC-72	4000	(8F) 500	FDDLC-72	4240	(8F) 500
	6000	(8F) 500 + (4H) 500		6240	(8F) 500 + (4H) 500

**Example: FDDLC-24 1480W has 2 full size 500 watt elements and 2 half size 200 watt elements**

# 10. PARTS LIST & EXPLODED VIEW

## FDC / FDLC / FDDC / FDDL-18 to 72 EXPLODED VIEW

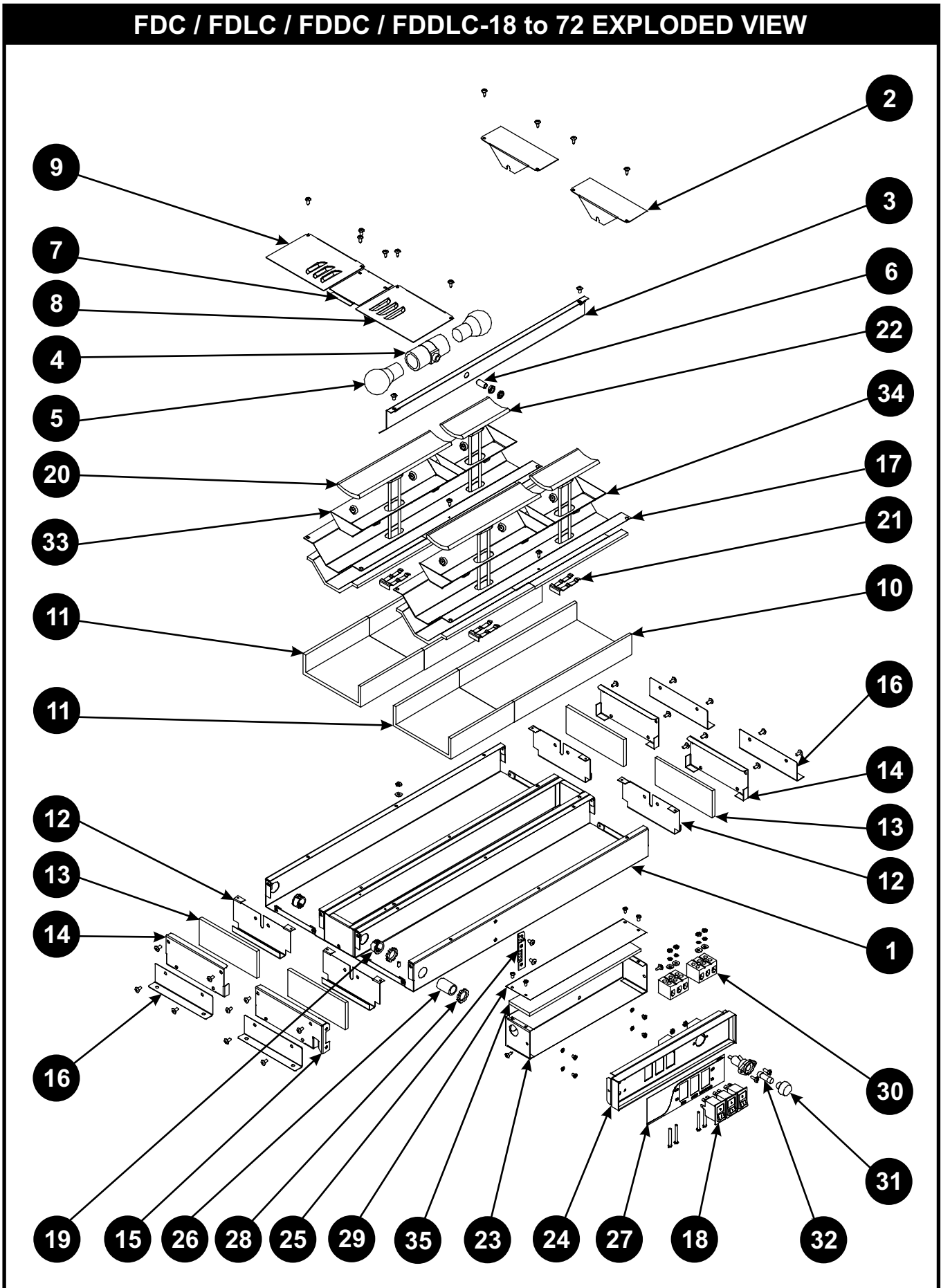

## FDC / FDLC / FDDC / FDDL-18 to 72 PARTS LIST

ITEM	P/N	DESCRIPTION	QUAN	ITEM	P/N	DESCRIPTION	QUAN
1	70476835	HOUSING W/ASS'Y FD-18	1	12	76804	SUPPORT ELEMENT FD	S-2 D-4
1	70476836	HOUSING W/ASS'Y FD-24	1	13	70402029	INSULATION 1/2 X 6 X 2-1/2 FD18-72	S-2 D-4
1	70476837	HOUSING W/ASS'Y FD-30	1	14	76803	END PLATE FD	S-1 D-3
1	70476838	HOUSING W/ASS'Y FD-36	1	15	70476803	PLATE, FDB AND C END	1
1	70476839	HOUSING W/ASS'Y FD-42	1	16	76955	BRACKET MOUNTING FD	S-2 D-4
1	70476840	HOUSING W/ASS'Y FD-48	1	17	70400002	REFLECTOR FD-18 LW (CERAMIC OVRHD)	S-1 D-2
1	70476841	HOUSING W/ASS'Y FD-54	1	17	70400009	REFLECTOR FD-24 LW (CERAMIC OVRHD)	S-1 D-2
1	70476842	HOUSING W/ASS'Y FD-60	1	17	70400014	REFLECTOR FD-30 LW (CERAMIC OVRHD)	S-1 D-2
1	70476843	HOUSING W/ASS'Y FD-66	1	17	70400019	REFLECTOR FD-36 LW (CERAMIC OVRHD)	S-1 D-2
1	70476844	HOUSING W/ASS'Y FD-72	1	17	70400024	REFLECTOR FD-42 LW (CERAMIC OVRHD)	S-1 D-2
1	70476845	HOUSING W/ASS'Y FDL-18	1	17	70400029	REFLECTOR FD-48 LW (CERAMIC OVRHD)	S-1 D-2
1	70476846	HOUSING W/ASS'Y FDL-24	1	17	70400034	REFLECTOR FD-54 LW (CERAMIC OVRHD)	S-1 D-2
1	70476847	HOUSING W/ASS'Y FDL-30	1	17	70400039	REFLECTOR FD-60 LW (CERAMIC OVRHD)	S-1 D-2
1	70476848	HOUSING W/ASS'Y FDL-36	1	17	70400044	REFLECTOR FD-66 LW (CERAMIC OVRHD)	S-1 D-2
1	70476849	HOUSING W/ASS'Y FDL-42	1	17	70400049	REFLECTOR FD-72 LW (CERAMIC OVRHD)	S-1 D-2
1	70476850	HOUSING W/ASS'Y FDL-48	1	17	70400054	REFLECTOR FD-18 HW (CERAMIC OVRHD)	S-1 D-2
1	70476851	HOUSING W/ASS'Y FDL-54	1	17	70400057	REFLECTOR FD-24 HW (CERAMIC OVRHD)	S-1 D-2
1	70476852	HOUSING W/ASS'Y FDL-60	1	17	70400060	REFLECTOR FD-30 HW (CERAMIC OVRHD)	S-1 D-2
1	70476853	HOUSING W/ASS'Y FDL-66	1	17	70400063	REFLECTOR FD-36 HW (CERAMIC OVRHD)	S-1 D-2
1	70476854	HOUSING W/ASS'Y FDL-72	1	17	70400066	REFLECTOR FD-42 HW (CERAMIC OVRHD)	S-1 D-2
1	70476855	HOUSING W/ASS'Y FDD/FDDL-18	1	17	70400069	REFLECTOR FD-48 HW (CERAMIC OVRHD)	S-1 D-2
1	70476856	HOUSING W/ASS'Y FDD/FDDL-24	1	17	70400072	REFLECTOR FD-54 HW (CERAMIC OVRHD)	S-1 D-2
1	70476857	HOUSING W/ASS'Y FDD/FDDL-30	1	17	70400075	REFLECTOR FD-60 HW (CERAMIC OVRHD)	S-1 D-2
1	70476858	HOUSING W/ASS'Y FDD/FDDL-36	1	17	70400078	REFLECTOR FD-66 HW (CERAMIC OVRHD)	S-1 D-2
1	70476859	HOUSING W/ASS'Y FDD/FDDL-42	1	17	70400081	REFLECTOR FD-72 HW (CERAMIC OVRHD)	S-1 D-2
1	70476860	HOUSING W/ASS'Y FDD/FDDL-48	1	18	70444800	SWITCH, ROCKER ON-OFF	V
1	70476861	HOUSING W/ASS'Y FDD/FDDL-54	1	19	89184	BUSHING, .875 HEYCO 2126	S-1 D-2
1	70476862	HOUSING W/ASS'Y FDD/FDDL-60	1	20	95100006	ELEMENT, CERAMIC, 120V, 500W, FTE	CHART A
1	70476863	HOUSING W/ASS'Y FDD/FDDL-66	1	20	94000028	ELEMENT, CERAMIC, 208V, 500W, FTE	CHART A
1	70476864	HOUSING W/ASS'Y FDD/FDDL-72	1	20	94400003	ELEMENT, CERAMIC, 240V, 500W, FTE	CHART A
2	76802	COVER SMALL FD	S-1 D-2	21	95000028	RETAINER, CERAMIC ELEMENT	V
3	76211	LIGHT SUPPORT W/A DL-18	1	22	70400084	ELEMENT, CERAMIC, 120V, 200W, HTE	CHART A
3	76212	LIGHT SUPPORT W/A DL-24	1	22	70400149	ELEMENT, CERAMIC, 208V, 200W, HTE	CHART A
3	76213	LIGHT SUPPORT W/A DL-30	1	22	70401149	ELEMENT, CERAMIC, 240V, 200W, HTE	CHART A
3	76214	LIGHT SUPPORT W/A DL-36	1	22	70400085	ELEMENT, CERAMIC, 120V, 150W, HTE	CHART A
3	76215	LIGHT SUPPORT W/A DL-42	1	22	70400150	ELEMENT, CERAMIC, 208V, 150W, HTE	CHART A
3	76216	LIGHT SUPPORT W/A DL-48	1	22	70401150	ELEMENT, CERAMIC, 240V, 150W, HTE	CHART A
3	76217	LIGHT SUPPORT W/A DL-54	1	22	70400083	ELEMENT, CERAMIC, 120V, 500W, HTE	CHART A
3	76218	LIGHT SUPPORT W/A DL-60	1	22	70400148	ELEMENT, CERAMIC, 208V, 500W, HTE	CHART A
3	76219	LIGHT SUPPORT W/A DL-66	1	22	70401148	ELEMENT, CERAMIC, 240V, 500W, HTE	CHART A
3	76220	LIGHT SUPPORT W/A DL-72	1	23	70476314	REMOTE ENCLOSURE, SINGLE CONTROL 8"	1
4	75917	LAMPHOLDER TWIN 660W/250V	V	23	70476316	REMOTE ENCLOSURE, SINGLE CONTROL 12"	1
5	75916	LAMP 40W COATED #40A15 120V	V	24	70421275	W/ASS'Y, REMOTE BOX COVER 12" W/FUSE	1
6	46877	NIPPLE, 1/8-27 X 3/4 PLATED	V	24	70401275	W/ASS'Y, REMOTE BOX COVER 12"	1
7	76159	COVER, END DL RH CONTROL	1	24	70411275	W/ASS'Y, REMOTE BOX COVER 8"	1
8	76801	COVER LARGE FD RH CTRL	1	24	70412275	W/ASS'Y, REMOTE BOX COVER 8"	1
9	76865	COVER LARGE FD LH CTRL	1	25	70400005	BRACKET, CONTROL BOX	1
10	70400146	INSULATION OVRHD WRMR 18-72	V	26	70400006	CONDUIT, ALUMINUM	1
10	70400147	INSULATION OVRHD WRMR 18-72	V	27	70401281	LABEL, FDDL CONTROL	1
11	70402028	INSULATION OVRHD WRMR 18-72	V	27	70402281	LABEL, FDDC CONTROL	1

V=QTY. VARIES  
FTE=Full Size Ceramic Element

S=SINGLE UNIT OR FDC/FDLC  
HTE=Half Size Ceramic Element

D=DOUBLE UNIT OR FDDC/FDDL  
N/S=NOT SHOWN

## FDC / FDLC / FDDC / FDDL-18 to 72 PARTS LIST (Continued)

ITEM	P/N	DESCRIPTION	QUAN	ITEM	P/N	DESCRIPTION	QUAN
27	70403281	LABEL, FDLC CONTROL	1	N/S	46876	NUT HEX 1/8 -27 PLATED	V
27	70404281	LABEL, FDC CONTROL	1	N/S	88961	NUT, HEX 10-24, GREEN	1
28	55102	LOCKNUT, 1/2 INCH CONDUIT	2	N/S	89042	SCREW 8-32 X 1/2 PH SL SS	2
29	70400007	PLATE, ACCESS	1	N/S	88889	SCREW #8 X 1/2 AB SMS PHL TRUSS	V
29	70401007	PLATE, 12 INCH ACCES	1	N/S	88993	SCREW 10-32X3/8 TRS HD PHL NYLK	V
30	70444700	BLOCK, TERMINAL, 3-POLE	V	N/S	89071	WASHER, #10 FLAT	V
31	85602	HOLDER, FUSE	1	N/S	89056	WASHER #8 INTERNAL LOCK, SS	V
32	85601	FUSE, BUS SC3 AMP	1	N/S	89039	SCREW, 8-32X5/16 PH PAN SS	1
33	70401011	SHIELD, FTE ELEMENT	V	N/S	88971	SCREW, 8-32x1-1/2 SL PN HD SS	4
34	70400011	SHIELD, HTE ELEMENT	V	N/S	89063	NUT, HEX 8-32	V
35	70402042	INSULATION, 12" CONTROL BOX	1	N/S	88954	SCREW,8-32X3/16,PH,PH,SS	4
35	70402043	INSULATION, 8" CONTROL BOX	1				

V=QTY. VARIES

FTE=Full Size Ceramic Element

S=SINGLE UNIT OR FDC/FDLC

HTE=Half Size Ceramic Element

D=DOUBLE UNIT OR FDDC/FDDL

N/S=NOT SHOWN

### Warranty Procedure

IF YOU NEED WARRANTY SERVICE FOR YOUR APW EQUIPMENT, FOLLOW THESE STEPS:

1. Secure the model and serial number from the data tag of your unit.
2. Non-portable equipment - The service agency will dispatch a technician to your location for repairs.
3. Portable equipment - If you request service at your location, you will be responsible for payment of travel and mileage charges. You can take the unit to the service agency to avoid these charges.
4. For the name of the closest authorized service/parts distributor consult the published list supplied by APW Wyott or call the APW Wyott Service Hot Line, 1-800-733-2203

#### IMPORTANT FOR FUTURE REFERENCE

Please complete this information and retain this manual for the life of the equipment. For Warranty Service and/or Parts, this information is required.

\_\_\_\_\_

Model Number

\_\_\_\_\_

Serial Number

\_\_\_\_\_

Date Purchased

**Notes:** \_\_\_\_\_

\_\_\_\_\_

\_\_\_\_\_

\_\_\_\_\_

\_\_\_\_\_

\_\_\_\_\_

\_\_\_\_\_

\_\_\_\_\_

\_\_\_\_\_

\_\_\_\_\_

\_\_\_\_\_

## 11. APW WYOTT EQUIPMENT LIMITED WARRANTY

APW Wyott Foodservice Equipment Company warrants its equipment against defects in materials and workmanship, subject to the following conditions:

This warranty applies to the original owner only and is not assignable.

Should any product fail to function in its intended manner under normal use within the limits defined in this warranty, at the option of APW Wyott such product will be repaired or replaced by APW Wyott or its Authorized Service Agency. APW Wyott will only be responsible for charges incurred or service performed by its Authorized Service Agencies. The use of other than APW Wyott Authorized Service Agencies will void this warranty and APW Wyott will not be responsible for such work or any charges associated with same. The closest APW Wyott Authorized Service Agent must be used.

This warranty covers products shipped into the 48 contiguous United States, Hawaii, metropolitan areas of Alaska and Canada. There will be no labor coverage for equipment located on any island not connected by roadway to the mainland.

Warranty coverage on products used outside the 48 contiguous United States, Hawaii, and metropolitan areas of Alaska and Canada may vary. Contact the international APW Wyott distributor, dealer, or service agency for details.

### Time Period

One year for parts and one year for labor, effective from the date of purchase by the original owner. The Authorized Service Agency may, at their option, require proof of purchase. Parts replaced under this warranty are warranted for the un-expired portion of the original product warranty only.

### Exceptions

\***Gas/Electric Cookline:** Models GCB, GCRB, GF, GGM, GGT, CHP-H, EF, EG, EHP. Three (3) Year Warranty on all component parts, except switches and thermostats. (2 additional years on parts only. No labor on second or third year.)

\***Broiler Briquettes, Rock Grates, Cooking Grates, Burner Shields, Fireboxes:** 90 Day Material Only. No Labor.

\***Heat Strips:** Models FD, FDL, FDD, FDDL. Two (2) Year Warranty on element only. No labor second year.

\***Glass Windows, Doors, Seals, Rubber Seals, Light Bulbs:** 90 Day Material Only. No Labor.

In all cases, parts covered by extended warranty will be shipped FOB the factory after the first year.

### Portable Carry In Products

Equipment weighing over 70 pounds or permanently installed will be serviced on-site as per the terms of this warranty. Equipment weighing 70 pounds or under, and which is not permanently installed, i.e. with cord and plug, is considered portable and is subject to the following warranty handling limitations. If portable equipment fails to operate in its intended manner on the first day of connection, or use, at APW Wyott's option or its Authorized Service Agency, it will be serviced on site or replaced.

From day two through the conclusion of this warranty period, portable units must be taken to or sent prepaid to the APW Wyott Authorized Service Agency for in-warranty repairs. No mileage or travel charges are allowed on portable units after the first day of use. If the customer wants on-site service, they may receive same by paying the travel and mileage charges. Exceptions to this rule: (1) countertop warmers and cookers, which are covered under the Enhanced Warranty Program, and (2) toasters or rollergrills which have in store service.

### Exclusions

The following conditions are not covered by warranty:

\*Equipment failure relating to improper installation, improper utility connection or supply and problems due to ventilation.

\*Equipment that has not been properly maintained, calibration of controls, adjustments, damage from improper cleaning and water damage to controls.

\*Equipment that has not been used in an appropriate manner, or has been subject to misuse or misapplication, neglect, abuse, accident, alteration, negligence, damage during transit, delivery or installation, fire, flood, riot or act of god.

\*Equipment that has the model number or serial number removed or altered.

If the equipment has been changed, altered, modified or repaired by other than an Authorized Service Agency during or after the warranty period, then the manufacturer shall not be liable for any damages to any person or to any property, which may result from the use of the equipment thereafter.

This warranty does not cover services performed at overtime or premium labor rates. Should service be required at times which normally involve overtime or premium labor rates, the owner shall be charged for the difference between normal service rates and such premium rates. APW Wyott does not assume any liability for extended delays in replacing or repairing any items beyond its control.

In all cases, the use of other than APW Wyott Authorized OEM Replacement Parts will void this warranty.

This equipment is intended for commercial use only. Warranty is void if equipment is installed in other than commercial application.

### Water Quality Requirements

Water supply intended for a unit that has in excess of 3.0 grains of hardness per gallon (GPG) must be treated or softened before being used. Water containing over 3.0 GPG will decrease the efficiency and reduce the operation life of the unit.

**Note: Product failure caused by liming or sediment buildup is not covered under warranty.**

**"THE FOREGOING WARRANTY IS IN LIEU OF ANY AND ALL OTHER WARRANTIES EXPRESSED OR IMPLIED INCLUDING ANY IMPLIED WARRANTY OF MERCHANTABILITY OR FITNESS FOR PARTICULAR PURPOSES AND CONSTITUTES THE ENTIRE LIABILITY OF APW WYOTT. IN NO EVENT DOES THE LIMITED WARRANTY EXTEND BEYOND THE TERMS STATED HEREIN."**

9/05