



*Ease\*Extreme*<sup>TM</sup>

**INSTALLATION  
AND  
OPERATING  
INSTRUCTIONS**



Model: **HDX**

**HOLDING DRAWERS**

**INTENDED FOR OTHER THAN HOUSEHOLD USE**

**RETAIN THIS MANUAL FOR FUTURE REFERENCE  
UNIT MUST BE KEPT CLEAR OF COMBUSTIBLES AT ALL TIMES**



**FOR YOUR SAFETY:** Do not store or use gasoline or other flammable vapors and liquids in the vicinity of this or any other appliance.



**WARNING:** Improper installation, adjustment, alteration, service or maintenance can cause property damage, injury or death. Read the Installation, Operating and Maintenance Instructions thoroughly before installing or servicing this equipment.



Initial heating of unit may generate smoke or fumes and must be done in a well ventilated area. Overexposure to smoke or fumes may cause nausea or dizziness.

This equipment has been engineered to provide you with year-round dependable service when used according to the instructions in this manual and standard commercial kitchen practices.



ANSI/NSF4

Phone: (214) 421-7366  
Fax: (214) 565-0976  
Toll Free: (800) 527-2100  
Website: [www.apwwyott.com](http://www.apwwyott.com)  
E-mail: [info@apwwyott.com](mailto:info@apwwyott.com)

P/N 70504626 9/05

**APW WYOTT**  
729 Third Avenue  
Dallas, TX 75226

# TABLE OF CONTENTS

SECTION	ITEM	PAGE
1	<b>Owner's Information</b> .....	2
	General Information.....	2
	General Operation Instructions.....	2
	Warranty Information.....	2
2	<b>Important Safety Information</b> .....	3
3	<b>Specifications</b> .....	3
	Electrical.....	3
	Dimensions.....	3
4	<b>Operation</b> .....	5
	Operating Instructions.....	5
5	<b>Parts Lists</b> .....	6
	HDX-1 Parts List w/Exploded View.....	6
	HDX-2 Parts List w/Exploded View.....	8
	HDX-3 Parts List w/Exploded View.....	10
	HDX-4 Parts List w/Exploded View.....	12
6	<b>Wiring Diagrams</b> .....	14
7	<b>Cleaning</b> .....	18
	General Cleaning Instructions.....	18
	Daily Cleaning.....	18
8	<b>Troubleshooting</b> .....	18
9	<b>Warranty</b> .....	20

## 1. OWNER'S INFORMATION

### General Information:

1. Always clean equipment thoroughly before first use. (See general cleaning instructions).
2. Check rating label for your model designation and electrical rating.
3. For best results, use stainless steel countertops.
4. All dimensions in parenthesis in centimeters unless noted.
5. Legs are shipped unassembled. Legs must be screwed into base of unit.

### General Operation Instructions:

1. All foodservice equipment should be operated by trained personnel.
2. Do not allow your customers to come in contact with any surface labeled "CAUTION HOT".
3. Where applicable: Never pour cold water into dry heated units.
4. Never hold food below 150°F (66°C).

### Warranty Information:

#### Reliability Backed By APW Wyott's Warranty:

All APW Wyott Holding Drawers are backed by a one year parts and labor warranty, including On-Site Service calls within 50 miles of authorized service technicians.

#### Service Information:

Service Hotline (800) 733-2203

## 2. SAFETY INFORMATION

APW Wyatt Holding Drawers are designed, built and sold for commercial use and should be operated by trained personnel only. Clearly post all CAUTIONS, WARNINGS and OPERATING INSTRUCTIONS near each unit to insure proper operation and to reduce the chance of personal injury and/or equipment damage.

Always disconnect power before servicing the Holding Drawer. Surfaces will remain hot after power has been turned off. Allow unit to cool before cleaning or servicing. Never clean the Holding Drawer by immersing it in water. The Holding Drawer is not protected against water jets; DO NOT CLEAN HOLDING DRAWER WITH A WATER JET. Always clean equipment before first use.

## 3. SPECIFICATIONS

### Cordset Configuration:

HDX-1-120 USES NEMA 5-15P      HDX-3-120 USES NEMA 5-15P  
 HDX-1-208 USES NEMA 6-15P      HDX-3-208 USES NEMA 6-15P  
 HDX-1-240 USES NEMA 6-15P      HDX-3-240 USES NEMA 6-15P

HDX-2-120 USES NEMA 5-15P      HDX-4-120 USES NEMA 5-20P  
 HDX-2-208 USES NEMA 6-15P      HDX-4-208 USES NEMA 6-15P  
 HDX-2-240 USES NEMA 6-15P      HDX-4-240 USES NEMA 6-15P



If the supply cord is damaged, the manufacturer or an authorized service agent or a similarly qualified person must replace it to avoid a hazard or voiding the warranty.

### Overall Dimensions & Electrical Specifications:

Model Number	Volts, Hz	Power Rating, Watts	Amps	Number of Drawers	Pan Size Inches	Overall Height Inches	Overall Width Inches	Overall Depth Inches	Weight
<b>HDX-1-120</b>	120, 60	450	3.8	1	12X20X6	20	25-1/2	21	84 LBS
<b>HDX-1-208</b>	208, 60	450	2.1	1	12X20X6	20	25-1/2	21	84 LBS
<b>HDX-1-240</b>	240, 60	450	1.8	1	12X20X6	20	25-1/2	21	84 LBS
<b>HDX-2-120</b>	120, 60	900	7.5	2	12X20X6	28	25-1/2	21	175 LBS
<b>HDX-2-208</b>	208, 60	900	4.3	2	12X20X6	28	25-1/2	21	175 LBS
<b>HDX-2-240</b>	240, 60	900	3.7	2	12X20X6	28	25-1/2	21	175 LBS
<b>HDX-3-120</b>	120, 60	1350	11.3	3	12X20X6	38	25-1/2	21	254 LBS
<b>HDX-3-208</b>	208, 60	1350	6.5	3	12X20X6	38	25-1/2	21	254 LBS
<b>HDX-3-240</b>	240, 60	1350	5.6	3	12X20X6	38	25-1/2	21	254 LBS
<b>HDX-4-120</b>	120, 60	1800	15	4	12X20X6	48	25-1/2	21	330 LBS
<b>HDX-4-208</b>	208, 60	1800	8.6	4	12X20X6	48	25-1/2	21	330 LBS
<b>HDX-4-240</b>	240, 60	1800	7.5	4	12X20X6	48	25-1/2	21	330 LBS

### HDX-1

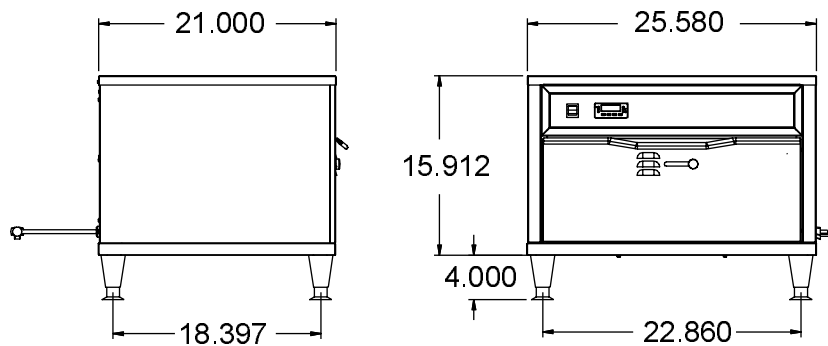

### HDX-2

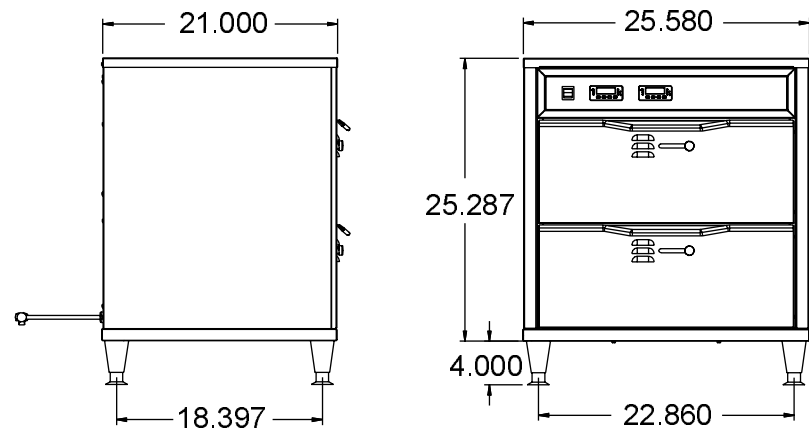

### HDX-3

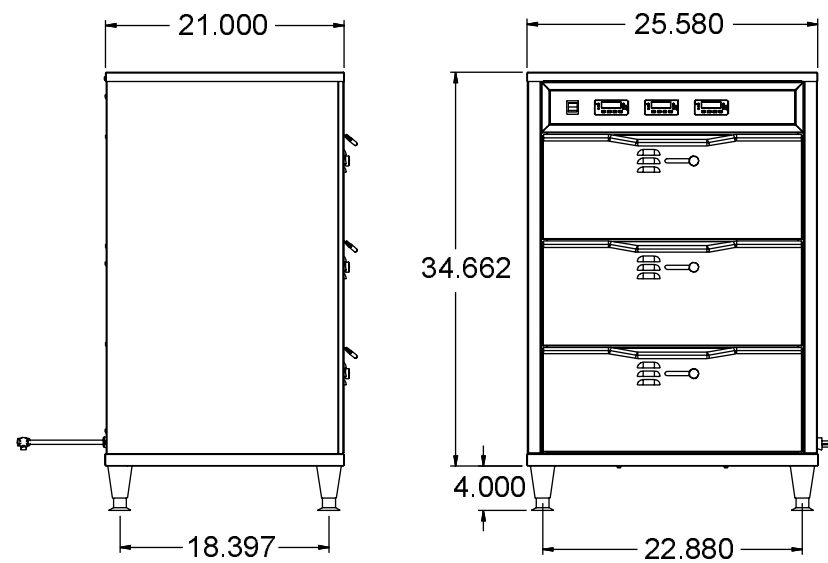

### HDX-4

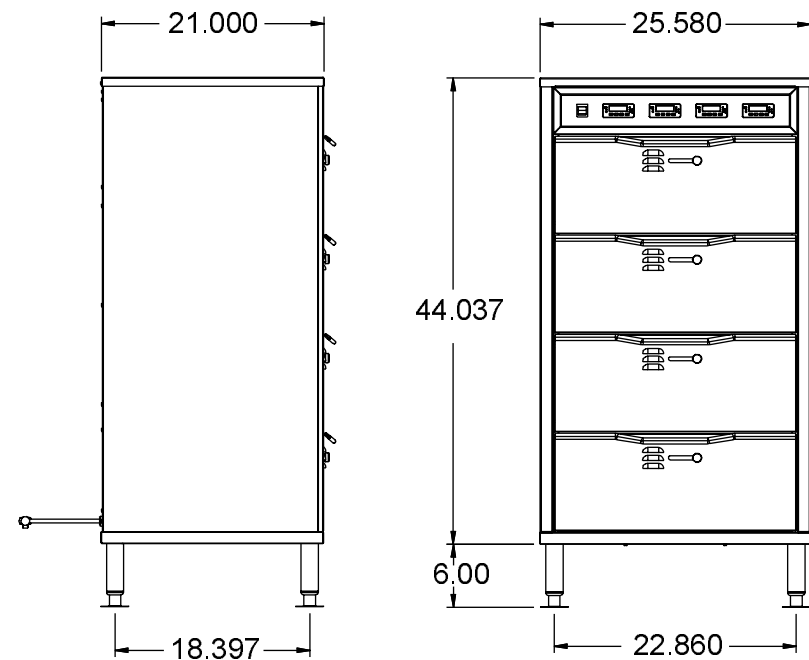



**WARNING:** ELECTRICAL SHOCK HAZARD. FAILURE TO FOLLOW THE INSTRUCTIONS IN THIS MANUAL COULD RESULT IN SERIOUS INJURY OR DEATH.



- Electrical Ground is required on this appliance.
- Do not modify the power supply cord plug. If it does not fit into the outlet, have the proper outlet installed by a qualified electrician
- Do not use an extension cord with this appliance.
- Check with a qualified electrician if you are unsure as to whether the appliance is properly grounded.

### Digital Controller Operation:

With unit plugged in and the rocker switch in the "ON" position, the digital controller will come on. When the controller is on, the minimum set point value is preset to 100°F and the maximum set point is 300°F. To obtain the desired set point, push the **set** key and release. **You have 2 seconds to adjust the set temperature.** Press the **up** or **down** key to your desired setting. After setting desired temperature, release **up** or **down** key and press the **set** key. The controller display should return to the measured temp range of the unit.

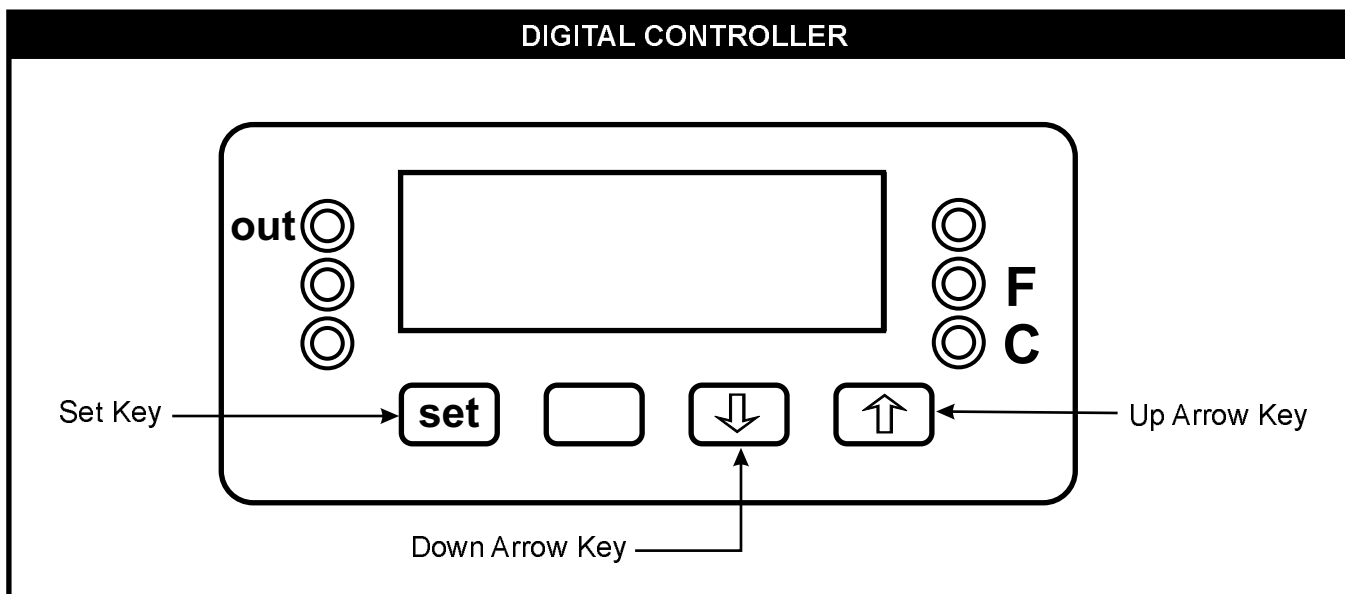

## 4. OPERATION

1. Set thermostat control to 190°F and preheat each drawer for 30 minutes.
2. Place food product directly in stainless steel drawer pans or use any combination of full or fractional pans up to 6" (152 mm) deep.
3. Set front vent to desired position for maintaining food product moisture.
4. Perforated pans may be used with damp towel or small amount of hot water in the drawer pan to prevent food "dry out".  
**CAUTION:** Use no more than 1 quart (1 liter) for wet operation.
5. If too much moisture accumulates around drawer front or vent, reduce temperature setting or move vent to "dry" position.

PRODUCT	TEMPERATURE SETTING	VENT
Rolls, Bread	160°-180° F (71°-82° C)	Moist
Vegetables	170°-180° F (77°-82° C)	Moist
Meats	170°-180° F (77°-82° C)	Moist

**NOTE:** Temperature and vent settings will require adjustment according to type and quantity of food, and number of times drawer is opened during operation.

# HDX-1 EXPLODED VIEW

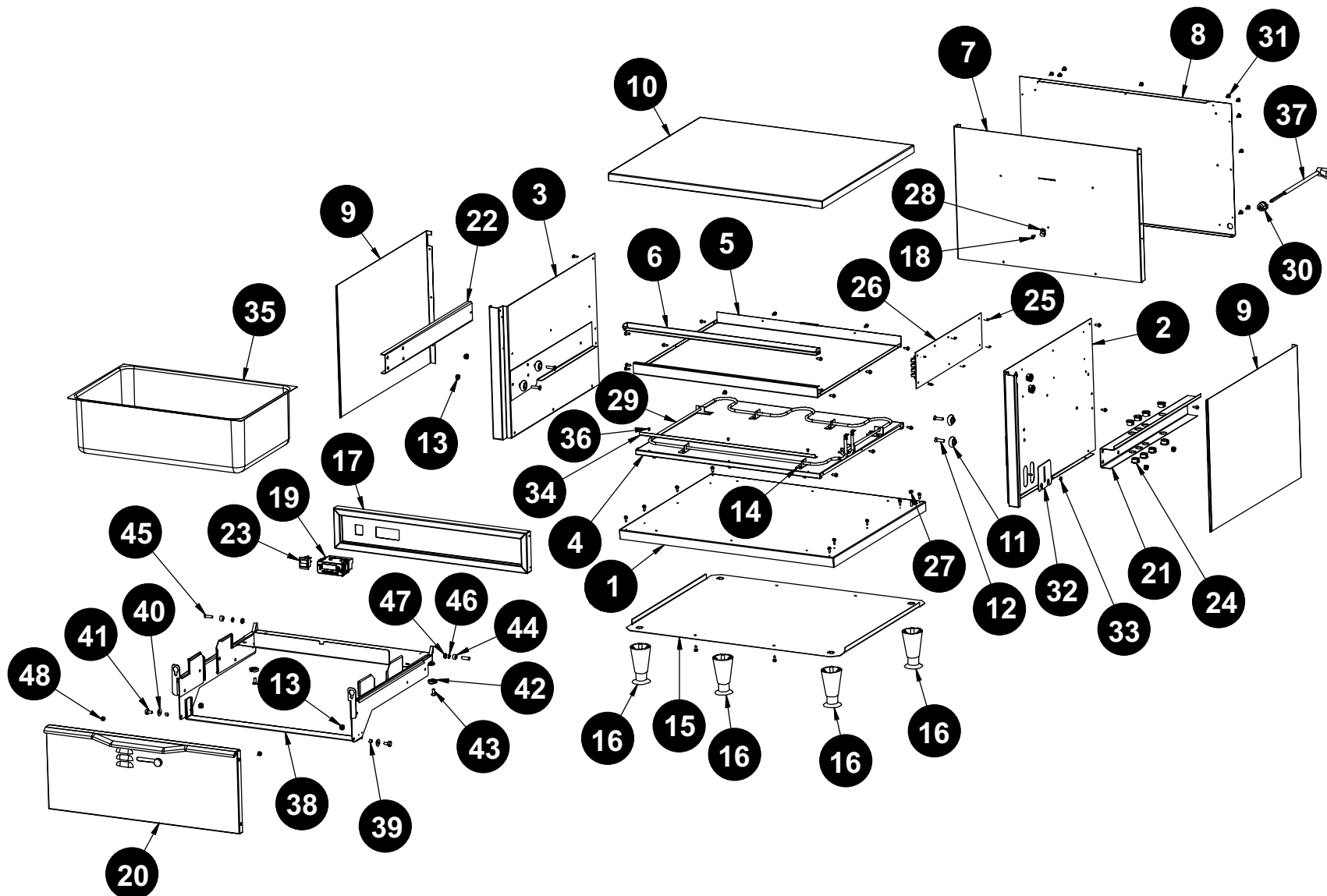

5. PARTS LISTS W/EXPLODED VIEWS

## HDX-1 PARTS LIST

ITEM	PART NUMBER	DESCRIPTION	QUAN	ITEM	PART NUMBER	DESCRIPTION	QUAN
1	70504101	WELD ASSY, BASE BOTTOM	1	26	70504624	S/A, COMPONENT PARTS	1
2	70504601	W/ASS'Y, RIGHT SIDE PANEL	1	27	88961	NUT, HEX 10-24, GREEN	1
3	70504605	W/ASS'Y, LEFT SIDE PANEL	1	28	70504812	P CLIP	1
4	70504100	W/ASS'Y, BOTTOM SHELF	1	29	70504805	HDX ELEMENT, 120V	1
5	70504087	SHELF, TOP	1		70504806	HDX ELEMENT, 208V	1
6	70504089	BRACE TOP	1		70504807	HDX ELEMENT, 240V	1
7	70504608	PANEL, INNER BACK	1	30	89111	BUSHING, STRAIN RELIEF SR-7W-2	1
8	70504609	PANEL, OUTER BACK	1	31	88889	SCREW #8 X 1/2 AB SMS PHL TRUSS	15
9	70504607	PANEL, OUTER RIGHT SIDE	2	32	70504625	ELEMENT, COVER	1
10	70504096	COVER, TOP	1	33	89063	NUT, HEX 8-32	1
11	33858	ROLLER, DRAWER SLIDE	4	34	70504815	DRIP, L-BRACKET	1
12	88892	SCREW, 1/4-20x1 FLAT HEAD SS	4	35	33018	PAN, SPECIAL 600 DRAWER	1
13	88893	NUT, 1/4-20 NYLON INSERT	6	36	56521	RIVET POP SS-42-D	17
14	32404	BRACKET, ELEMENT	7	37	55970	CORD, 120 VOLT 15A	1
15	70504127	BOTTOM COVER	1	38	70504121	W/ASSY, DRAWER HOUSING	1
16	86295	LEG, 4"-BLACK	4	39	70504817	STAINLESS STEEL, BUSHING	2
17	70504040	CONTROL PANEL	1	40	87441	WASHER .250 id x .47/64 od x .065 thk	2
18	89073	SCREW, #8 X 1/2 HEX	49	41	89003	BOLT, 1/4-20 X 1/2" SS HEX	2
19	70101025	TEMP. CONTROLLER, DIGITAL 208-240V	1	42	70502042	FLAT BEARING W/ HOLE	2
	70101031	TEMP. CONTROLLER, DIGITAL 115V	1	43	70502028	SCREW, 1/4-20x FLAT HEAD SS	2
20	70504107	S/ASSY, DRAWER FACE	1	44	88852	BUSHING, SLIDE	2
21	70504618	BRACKET, STIFFNER	1	45	88894	STUD PRESS THREADED	2
22	70502041	BRACKET, STIFFNER	1	46	89076	WASHER, LOCK 1/4 INTERNAL	2
23	89491	SWITCH, ROCKER	1	47	89163	NUT, JAM HEX 1/4-20 N.P. SS	2
24	89207	HEYCO BUSHING .750 P/N 2093	10	48	87074	PIN, HANGER	2
25	88989	STANDOFF, #4-40, MALE /FEMALE	6				

# HDX-2 EXPLODED VIEW

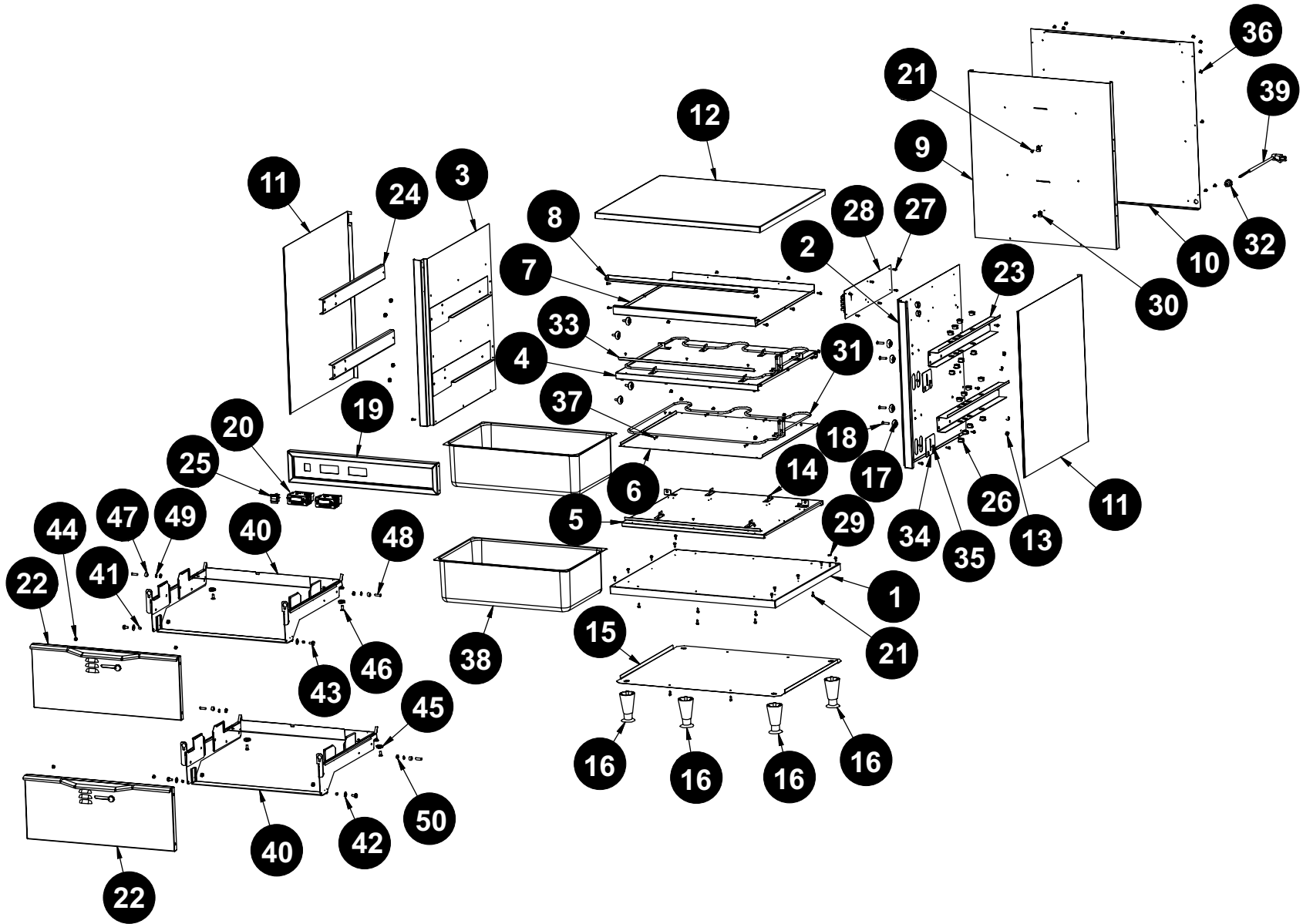

## HDX-2 PARTS LIST

ITEM	PART NUMBER	DESCRIPTION	QUAN	ITEM	PART NUMBER	DESCRIPTION	QUAN
1	70504101	WELD ASSY, BASE BOTTOM	1	25	89491	SWITCH, ROCKER	1
2	70504102	W/ASS'Y, RIGHT SIDE PANEL	1	26	89207	HEYCO BUSHING .750 P/N 2093	18
3	70504103	W/ASS'Y, LEFT SIDE PANEL	1	27	88989	STANDOFF, #4-40, MALE /FEMALE	6
4	70504801	SHELF, MIDDLE	1	28	70504623	S/A, COMPONENT PARTS	1
5	70504100	W/ASS'Y, BOTTOM SHELF	1	29	88961	NUT, HEX 10-24, GREEN	1
6	32417	COVER, SHELF	1	30	70504812	P CLIP	2
7	70504087	SHELF, TOP	1	31	70504805	HDX ELEMENT, 120V	2
8	70504089	BRACE TOP	1		70504806	HDX ELEMENT, 208V	2
9	70504091	PANEL, INNER BACK	1		70504807	HDX ELEMENT, 240V	2
10	70504090	PANEL, OUTER BACK	1	32	89111	BUSHING, STRAIN RELIEF SR-7W-2	1
11	70504094	PANEL, OUTER RIGHT SIDE	2	33	70504815	DRIP, L-BRACKET	2
12	70504096	COVER, TOP	1	34	70504625	ELEMENT, COVER	2
13	88893	NUT, 1/4-20 NYLON INSERT	12	35	89063	NUT, HEX 8-32	2
14	32404	BRACKET, ELEMENT	14	36	88889	SCREW #8 X 1/2 AB SMS PHL TRUSS	17
15	70504127	BOTTOM COVER	1	37	56521	RIVET POP SS-42-D	34
16	86295	LEG, 4"-BLACK (Standard)	4	38	33018	PAN, SPECIAL 600 DRAWER	2
	33266	Swivel Caster (Front of Unit) Optional	2	39	55970	CORD, 120 VOLT 15A	1
	33265	Rigid Caster (Rear of Unit) Optional	2	40	70504121	W/ASSY, DRAWER HOUSING	2
	70504814	Leg, 6" (Optional)	4	41	70504817	STAINLESS STEEL, BUSHING	4
17	33858	ROLLER, DRAWER SLIDE	8	42	87441	WASHER .250 id x .47/64 od x .065 thk	4
18	88892	SCREW, 1/4-20x1 FLAT HEAD SS	8	43	89003	BOLT, 1/4-20 X 1/2" SS HEX	4
19	70504017	CONTROL PANEL	1	44	87074	PIN, HANGER	4
20	70101025	TEMP. CONTROLLER, DIGITAL 208-240V	2	45	70502042	FLAT BEARING W/ HOLE	4
	70101031	TEMP. CONTROLLER, DIGITAL 115V	2	46	70502028	SCREW, 1/4-20x FLAT HEAD SS	4
21	89073	SCREW, #8 X 1/2 HEX	68	47	88852	BUSHING, SLIDE	4
22	70504107	S/ASSY, DRAWER FACE	2	48	88894	STUD PRESS THREADED	4
23	70504618	BRACKET, STIFFNER	2	49	89076	WASHER, LOCK 1/4 INTERNAL	4
24	70502041	BRACKET, STIFFNER	2	50	89163	NUT, JAM HEX 1/4-20 N.P. SS	4

# HDX-3 EXPLODED VIEW

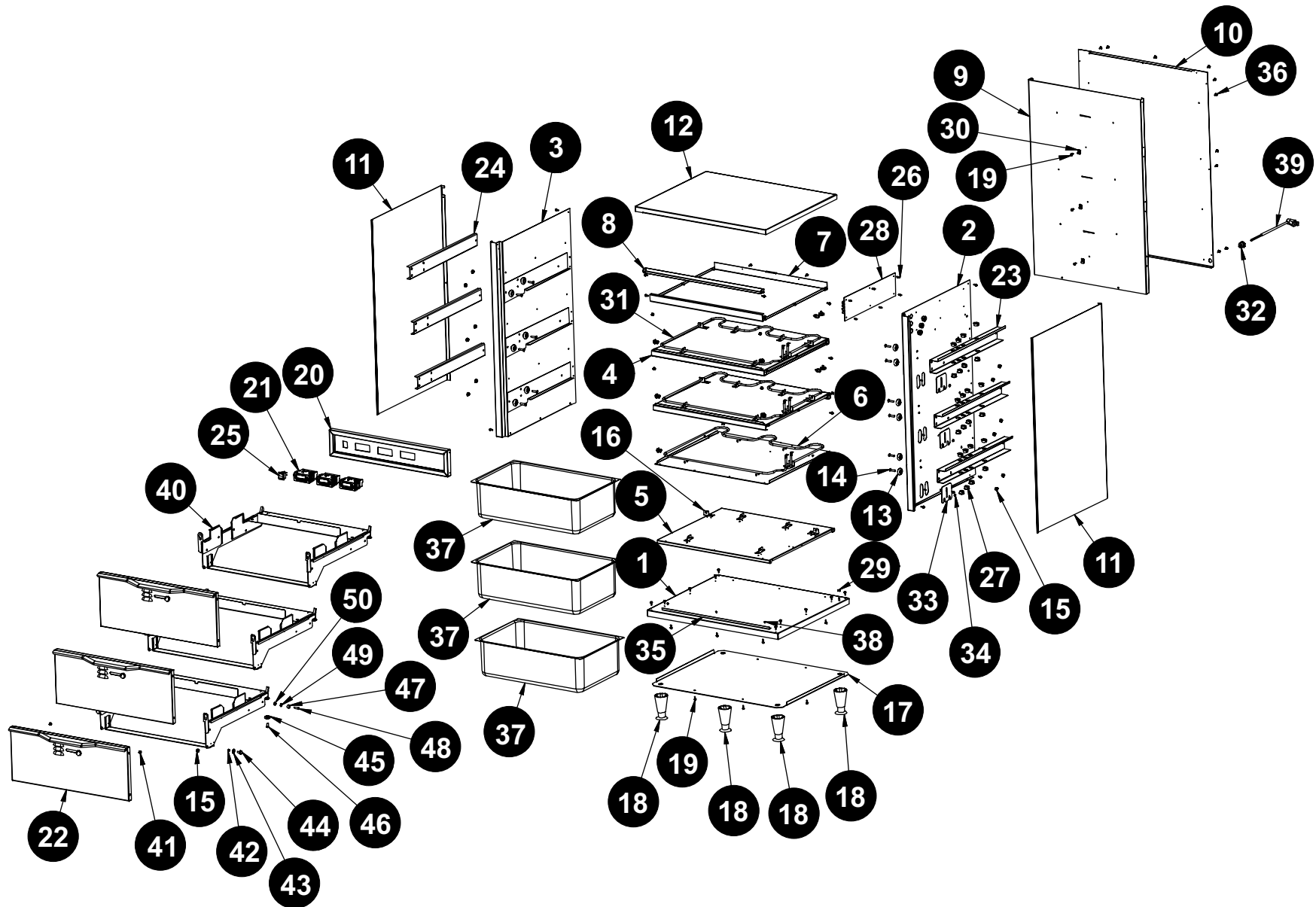

## HDX-3 PARTS LIST

ITEM	PART NUMBER	DESCRIPTION	QUAN	ITEM	PART NUMBER	DESCRIPTION	QUAN
1	70504101	WELD ASSY, BASE BOTTOM	1	25	89491	SWITCH, ROCKER	1
2	70504304	W/ASS'Y, RIGHT SIDE PANEL	1	26	88989	STANDOFF, #4-40, MALE /FEMALE	6
3	70504307	W/ASS'Y, LEFT SIDE PANEL	1	27	89207	HEYCO BUSHING .750 P/N 2093	27
4	70504801	SHELF, MIDDLE	2	28	70504622	S/A, COMPONENT PARTS	1
5	70504100	W/ASS'Y, BOTTOM SHELF	1	29	88961	NUT, HEX 10-24, GREEN	1
6	32417	COVER, SHELF	2	30	70504812	P CLIP	3
7	70504087	SHELF, TOP	1	31	70504805	HDX ELEMENT, 120V	3
8	70504089	BRACE TOP	1		70504806	HDX ELEMENT, 208V	3
9	70504311	PANEL, INNER BACK	1		70504807	HDX ELEMENT, 240V	3
10	70504309	PANEL, OUTER BACK	1	32	89111	BUSHING, STRAIN RELIEF SR-7W-2	1
11	70504310	PANEL, OUTER RIGHT SIDE	2	33	70504625	ELEMENT, COVER	3
12	70504096	COVER, TOP	1	34	89063	NUT, HEX 8-32	3
13	33858	ROLLER, DRAWER SLIDE	12	35	70504815	DRIP, L-BRACKET	3
14	88892	SCREW, 1/4-20x1 FLAT HEAD SS	12	36	88889	SCREW #8 X 1/2 AB SMS PHL TRUSS	17
15	88893	NUT, 1/4-20 NYLON INSERT	18	37	33018	PAN, SPECIAL 600 DRAWER	3
16	32404	BRACKET, ELEMENT	21	38	56521	RIVET POP SS-42-D	51
17	70504127	BOTTOM COVER	1	39	55970	CORD, 120 VOLT 15A	1
18	86295	LEG, 4"-BLACK (Standard)	4	40	70504121	W/ASSY, DRAWER HOUSING	3
	33266	Swivel Caster (Front of Unit) Optional	2	41	87074	PIN, HANGER	6
	33265	Rigid Caster (Rear of Unit) Optional	2	42	70504817	STAINLESS STEEL, BUSHING	6
	70504814	Leg, 6" (Optional)	4	43	87441	WASHER .250 id x .47/64 od x .065 thk	6
19	89073	SCREW, #8 X 1/2 HEX	74	44	89003	BOLT, 1/4-20 X 1/2" SS HEX	6
20	70504041	CONTROL PANEL	1	45	70502042	FLAT BEARING W/ HOLE	6
21	70101025	TEMP. CONTROLLER, DIGITAL 208-240V	3	46	70502028	SCREW, 1/4-20x FLAT HEAD SS	6
	70101031	TEMP. CONTROLLER, DIGITAL 115V	3	47	88852	BUSHING, SLIDE	6
22	70504107	S/ASSY, DRAWER FACE	3	48	88894	STUD PRESS THREADED	6
23	70504618	BRACKET, STIFFNER	3	49	89076	WASHER, LOCK 1/4 INTERNAL	6
24	70502041	BRACKET, STIFFNER	3	50	89163	NUT, JAM HEX 1/4-20 N.P. SS	6

# HDX-4 EXPLODED VIEW

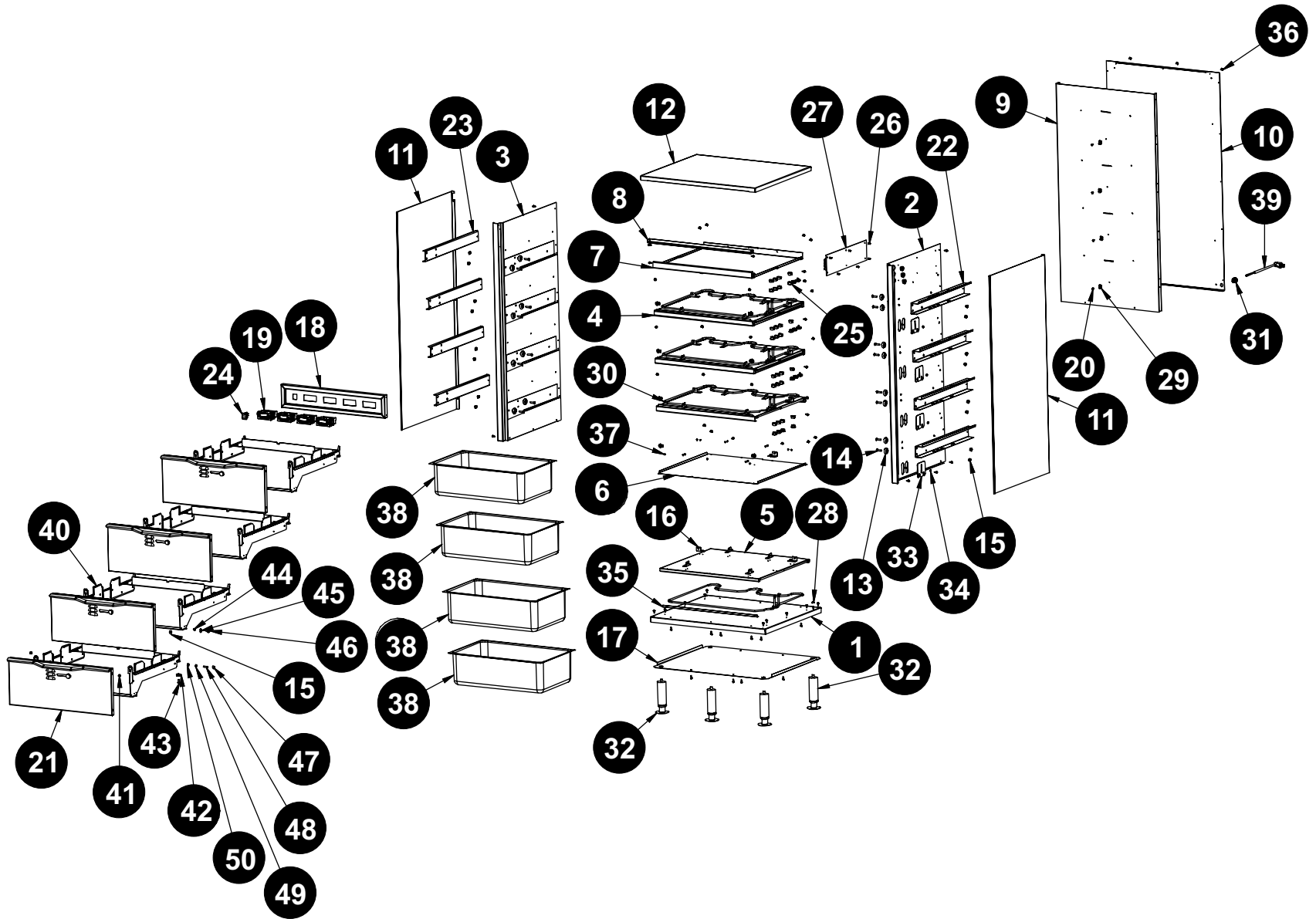

## HDX-4 PARTS LIST

ITEM	PART NUMBER	DESCRIPTION	QUAN	ITEM	PART NUMBER	DESCRIPTION	QUAN
1	70504101	WELD ASSY, BASE BOTTOM	1	28	88961	NUT, HEX 10-24, GREEN	1
2	70504401	W/ASS'Y, RIGHT SIDE PANEL	1	29	70504812	P CLIP	4
3	70504403	W/ASS'Y, LEFT SIDE PANEL	1	30	70504805	HDX ELEMENT, 120V	4
4	70504801	SHELF, MIDDLE	3		70504806	HDX ELEMENT, 208V	4
5	70504100	W/ASS'Y, BOTTOM SHELF	1		70504807	HDX ELEMENT, 240V	4
6	32417	COVER, SHELF	3	31	89111	BUSHING, STRAIN RELIEF SR-7W-2	1
7	70504087	SHELF, TOP	1	32	70504814	6" ADJUSTABLE LEG (Standard)	4
8	70504089	BRACE TOP	1		33266	Swivel Caster (Front of Unit) Optional	2
9	70504406	PANEL, INNER BACK	1		33265	Rigid Caster (Rear of Unit) Optional	2
10	70504407	PANEL, OUTER BACK	1	33	70504625	ELEMENT, COVER	4
11	70504405	PANEL, OUTER RIGHT SIDE	2	34	89063	NUT, HEX 8-32	4
12	70504096	COVER, TOP	1	35	70504815	DRIP, L-BRACKET	4
13	33858	ROLLER, DRAWER SLIDE	16	36	88889	SCREW #8 X 1/2 AB SMS PHL TRUSS	19
14	88892	SCREW, 1/4-20x1 FLAT HEAD SS	16	37	56521	RIVET POP SS-42-D	68
15	88893	NUT, 1/4-20 NYLON INSERT	24	38	33018	PAN, SPECIAL 600 DRAWER	4
16	32404	BRACKET, ELEMENT	28	39	55970	CORD, 120 VOLT 15A	1
17	70504127	BOTTOM COVER	1	40	70504121	W/ASSY, DRAWER HOUSING	4
18	70504043	CONTROL PANEL	1	41	87074	PIN, HANGER	8
19	70101025	TEMP. CONTROLLER, DIGITAL 208-240V	4	42	70502042	FLAT BEARING W/ HOLE	8
	70101031	TEMP. CONTROLLER, DIGITAL 115V	4	43	70502028	SCREW, 1/4-20x FLAT HEAD SS	8
20	89073	SCREW, #8 X 1/2 HEX	88	44	70504817	STAINLESS STEEL, BUSHING	8
21	70504107	S/ASSY, DRAWER FACE	4	45	87441	WASHER .250 id x .47/64 od x .065 thk	8
22	70504618	BRACKET, STIFFNER	4	46	89003	BOLT, 1/4-20 X 1/2" SS HEX	8
23	70502041	BRACKET, STIFFNER	4	47	88852	BUSHING, SLIDE	8
24	89491	SWITCH, ROCKER	1	48	88894	STUD PRESS THREADED	8
25	89207	HEYCO BUSHING .750 P/N 2093	35	49	89076	WASHER, LOCK 1/4 INTERNAL	8
26	88989	#4-40 MALE/FEMALE STANDOFF	6	50	89163	NUT, JAM HEX 1/4-20 N.P. SS	8
27	70504621	S/A, COMPONENT PARTS	1				

# 6. WIRING DIAGRAMS

## HDX-1 (120, 208 & 240V)

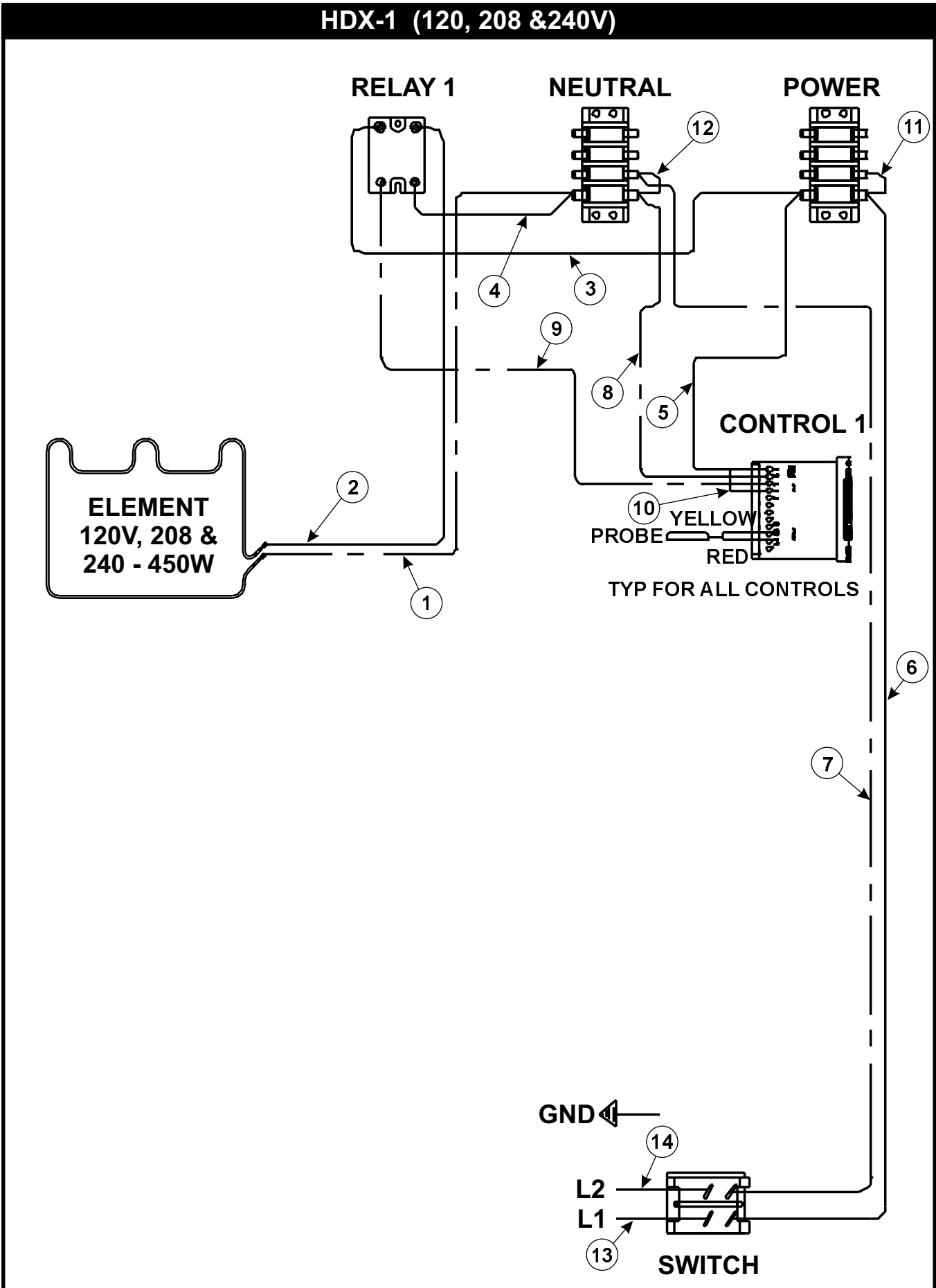

# HDX-2 (120, 208 & 240V)

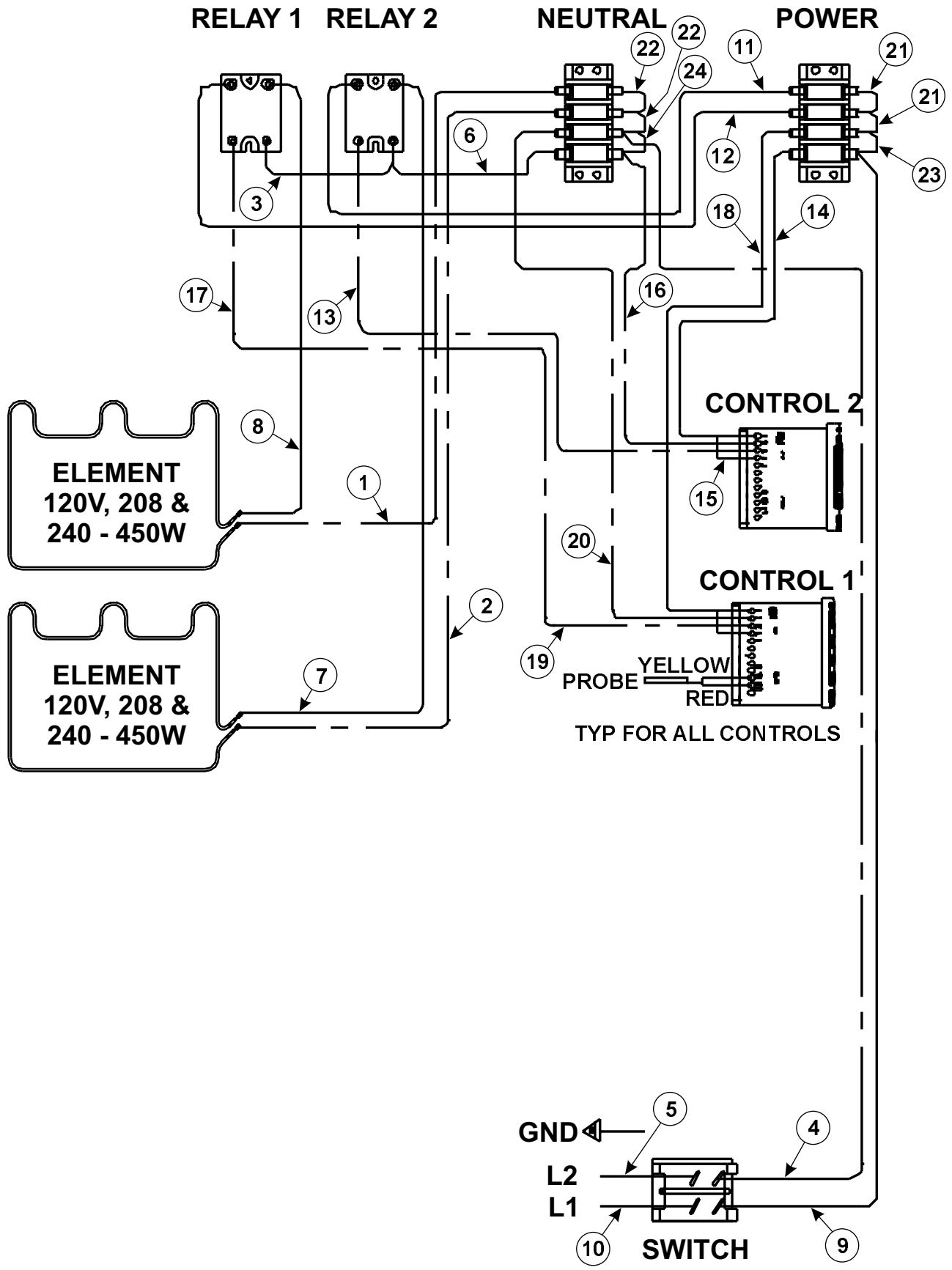

# HDX-3 (120, 208 & 240V)

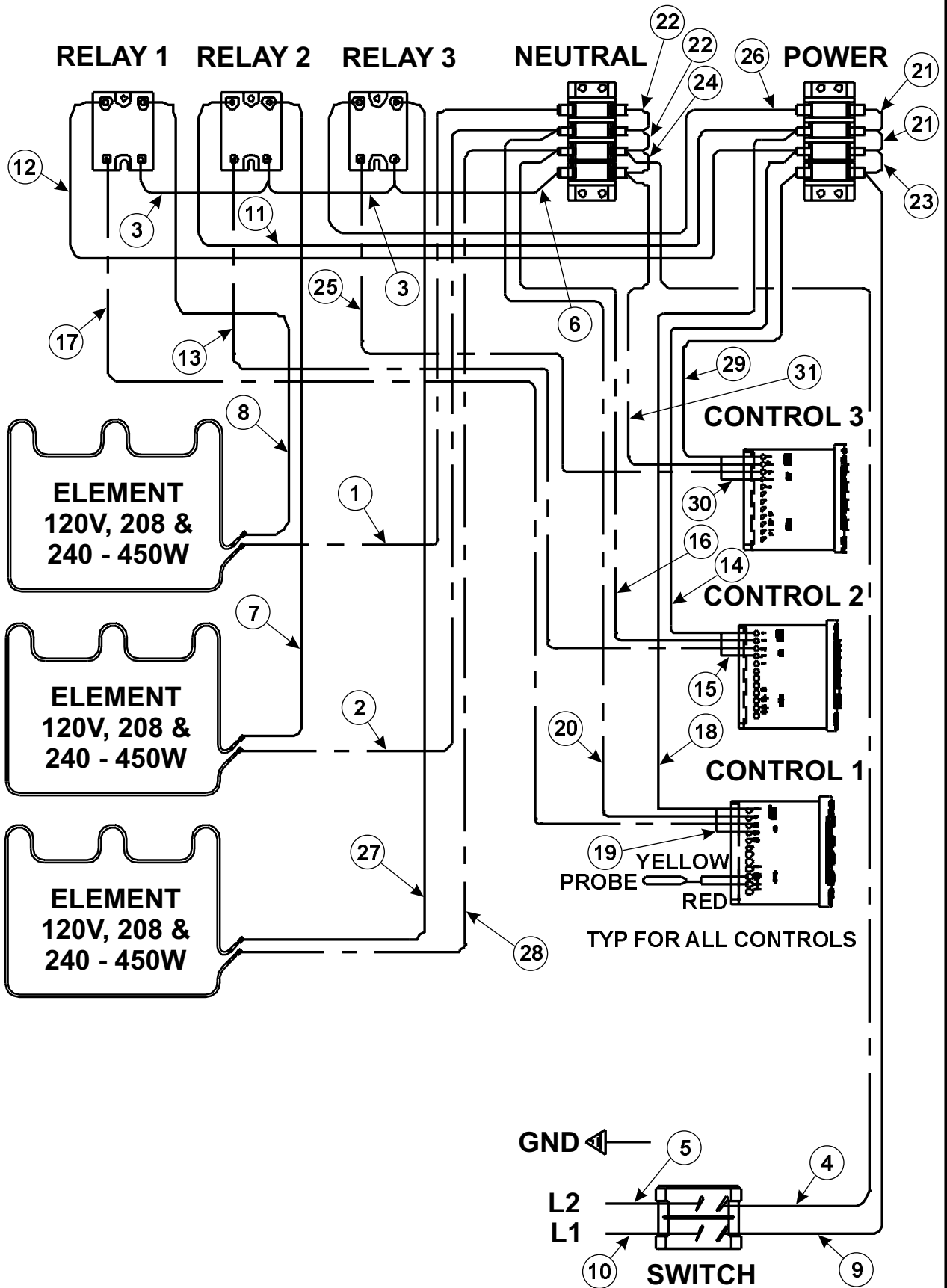

# HDX-4 (120, 208 & 240V)

RELAY 1 RELAY 2 RELAY 3 RELAY 4

NEUTRAL POWER

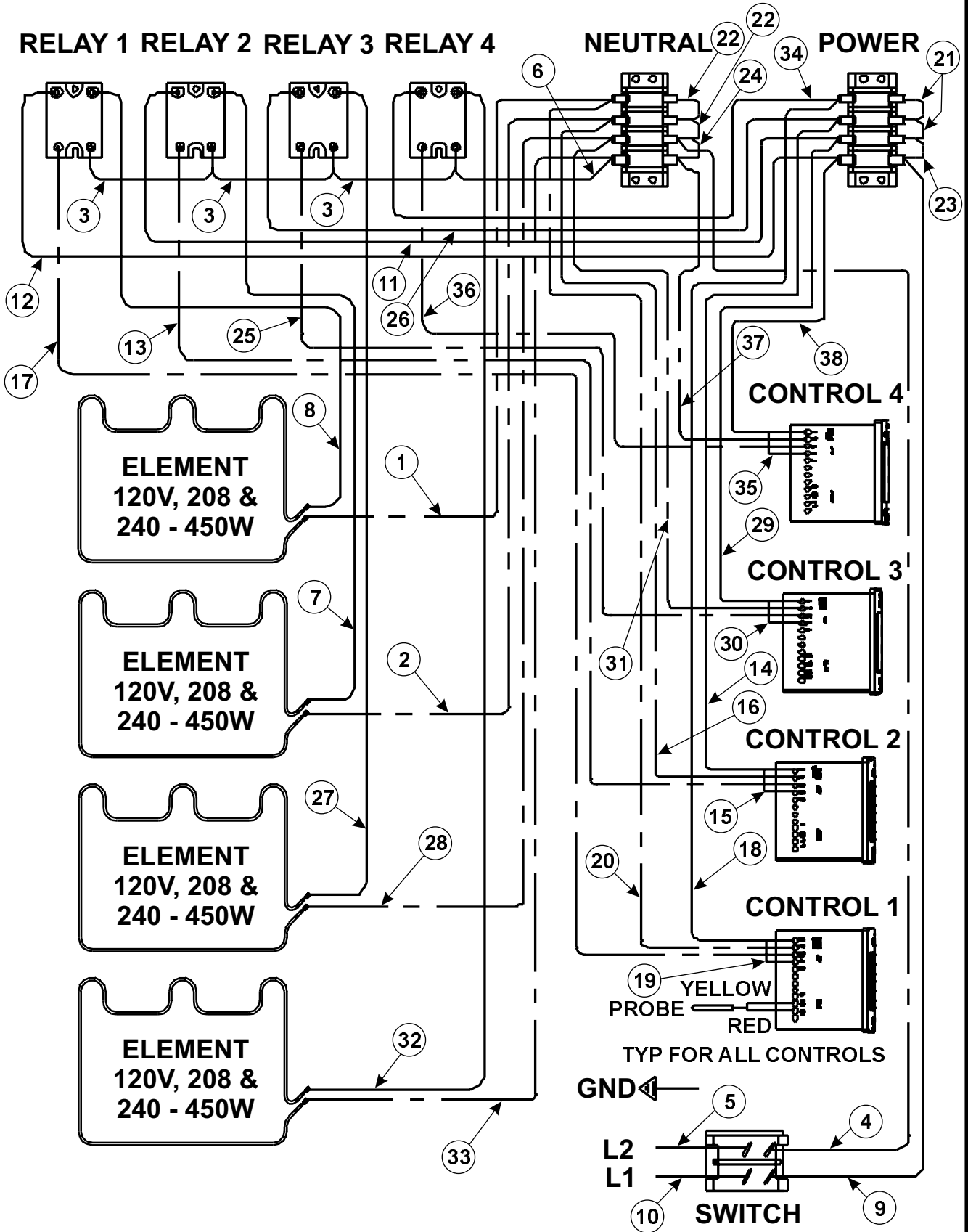

## **7. CLEANING**

### **General Cleaning Instructions:**

1. NEVER clean any electrical unit by immersing it in water. Turn off before surface cleaning.
2. Always clean equipment thoroughly before first use. Clean unit daily. Except where noted on charts: Use warm, soapy water. Mild cleansers and PLASTIC scouring pads may be used to remove baked-on food and water scale.
3. Turn off electrical units before cleaning or servicing. All service should be performed by an APW authorized service agency.

### **Daily Cleaning:**

1. Follow General Cleaning instructions (above).
2. Remove any inset pans and drawer pans. Wash thoroughly in the sink or dishwasher.
3. Remove drawers: Remove pans and pan inserts. Extend drawer and lift up on the front to clear the drawer stop. Lower drawer and pull straight out.

## **8. TROUBLESHOOTING GUIDE**

### **Always ask and check the following:**

1. Is the unit connected to a live power source of the proper voltage?
2. Check the circuit breaker.
3. Is power switch "ON" and pilot light glowing?
4. Check the rating label. Is the unit connected to the correct power source?



## 9. APW WYOTT EQUIPMENT LIMITED WARRANTY

APW Wyott Foodservice Equipment Company warrants its equipment against defects in materials and workmanship, subject to the following conditions:

This warranty applies to the original owner only and is not assignable.

Should any product fail to function in its intended manner under normal use within the limits defined in this warranty, at the option of APW Wyott such product will be repaired or replaced by APW Wyott or its Authorized Service Agency. APW Wyott will only be responsible for charges incurred or service performed by its Authorized Service Agencies. The use of other than APW Wyott Authorized Service Agencies will void this warranty and APW Wyott will not be responsible for such work or any charges associated with same. The closest APW Wyott Authorized Service Agent must be used.

This warranty covers products shipped into the 48 contiguous United States, Hawaii, metropolitan areas of Alaska and Canada. There will be no labor coverage for equipment located on any island not connected by roadway to the mainland.

Warranty coverage on products used outside the 48 contiguous United States, Hawaii, and metropolitan areas of Alaska and Canada may vary. Contact the international APW Wyott distributor, dealer, or service agency for details.

### Time Period

One year for parts and one year for labor, effective from the date of purchase by the original owner. The Authorized Service Agency may, at their option, require proof of purchase. Parts replaced under this warranty are warranted for the un-expired portion of the original product warranty only.

### Exceptions

- \***Gas/Electric Cookline:** Models GCB, GCRB, GF, GGM, GGT, CHP-H, EF, EG, EHP. Three (3) Year Warranty on all component parts, except switches and thermostats. (2 additional years on parts only. No labor on second or third year.)
- \***Broiler Briquettes, Rock Grates, Cooking Grates, Burner Shields, Fireboxes:** 90 Day Material Only. No Labor.
- \***Heat Strips:** Models FD, FDL, FDD, FDDL. Two (2) Year Warranty on element only. No labor second year.
- \***Glass Windows, Doors, Seals, Rubber Seals, Light Bulbs:** 90 Day Material Only. No Labor.

In all cases, parts covered by extended warranty will be shipped FOB the factory after the first year.

### Portable Carry In Products

Equipment weighing over 70 pounds or permanently installed will be serviced on-site as per the terms of this warranty. Equipment weighing 70 pounds or under, and which is not permanently installed, i.e. with cord and plug, is considered portable and is subject to the following warranty handling limitations. If portable equipment fails to operate in its intended manner on the first day of connection, or use, at APW Wyott's option or its Authorized Service Agency, it will be serviced on site or replaced.

From day two through the conclusion of this warranty period, portable units must be taken to or sent prepaid to the APW Wyott Authorized Service Agency for in-warranty repairs. No mileage or travel charges are allowed on portable units after the first day of use. If the customer wants on-site service, they may receive same by paying the travel and mileage charges. Exceptions to this rule: (1) countertop warmers and cookers, which are covered under the Enhanced Warranty Program, and (2) toasters or rollergrills which have in store service.

### Exclusions

The following conditions are not covered by warranty:

- \*Equipment failure relating to improper installation, improper utility connection or supply and problems due to ventilation.
- \*Equipment that has not been properly maintained, calibration of controls, adjustments, damage from improper cleaning and water damage to controls.
- \*Equipment that has not been used in an appropriate manner, or has been subject to misuse or misapplication, neglect, abuse, accident, alteration, negligence, damage during transit, delivery or installation, fire, flood, riot or act of god.
- \*Equipment that has the model number or serial number removed or altered.

If the equipment has been changed, altered, modified or repaired by other than an Authorized Service Agency during or after the warranty period, then the manufacturer shall not be liable for any damages to any person or to any property, which may result from the use of the equipment thereafter.

This warranty does not cover services performed at overtime or premium labor rates. Should service be required at times which normally involve overtime or premium labor rates, the owner shall be charged for the difference between normal service rates and such premium rates. APW Wyott does not assume any liability for extended delays in replacing or repairing any items beyond its control.

In all cases, the use of other than APW Wyott Authorized OEM Replacement Parts will void this warranty.

This equipment is intended for commercial use only. Warranty is void if equipment is installed in other than commercial application.

### Water Quality Requirements

Water supply intended for a unit that has in excess of 3.0 grains of hardness per gallon (GPG) must be treated or softened before being used. Water containing over 3.0 GPG will decrease the efficiency and reduce the operation life of the unit.

**Note: Product failure caused by liming or sediment buildup is not covered under warranty.**

**“THE FOREGOING WARRANTY IS IN LIEU OF ANY AND ALL OTHER WARRANTIES EXPRESSED OR IMPLIED INCLUDING ANY IMPLIED WARRANTY OF MERCHANTABILITY OR FITNESS FOR PARTICULAR PURPOSES AND CONSTITUTES THE ENTIRE LIABILITY OF APW WYOTT. IN NO EVENT DOES THE LIMITED WARRANTY EXTEND BEYOND THE TERMS STATED HEREIN.”**

9/05